



وزارة التعليم العالي والبحث العلمي  
جامعة الفرات الاوسط التقنية  
المعهد التقني / بابل  
قسم تقنيات ميكانيك القدرة

# Engineering Mechanics

محاضرات الميكانيك الهندسي  
المرحلة الاولى  
العام الدراسي 2026/2025

اعداد

م.د بشار ضياء حسين

ENGINEERING MECHANICS

**FORCE:** any action which change or try to change the shape, volume or the motion of a body .

**Classification of forces:**

- 1- Collinear
- 2- Parallel forces
- 3- Concurrent forces
- 4- Non parallel, non-concurrent forces

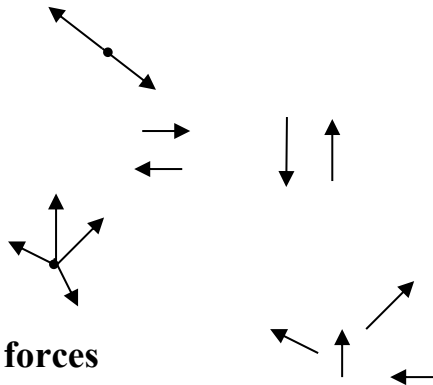

**Right angle triangle:**

$\sin \alpha = BC/AC \Rightarrow BC = AC \sin \alpha$   
 $\cos \alpha = AB/AC \Rightarrow AB = AC \cos \alpha$

$\tan \alpha = BC/AB$   
 $(AC)^2 = (AB)^2 + (BC)^2$

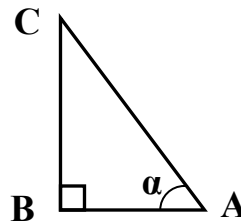

**Parallelogram:**

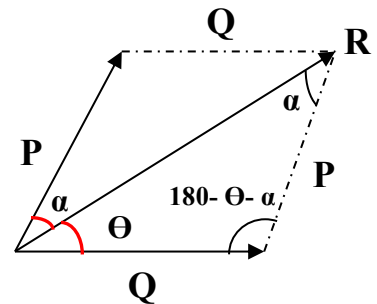
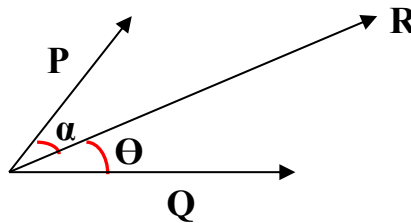
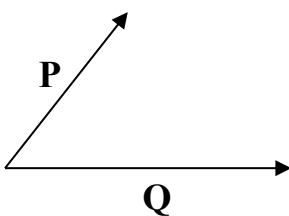

**Cos. Law:**

$$R^2 = P^2 + Q^2 - 2PQ \cos(180 - \theta - \alpha)$$

**Sin. Law:**

$$\frac{R}{\sin(180 - \theta - \alpha)} = \frac{P}{\sin \theta} = \frac{Q}{\sin \alpha}$$

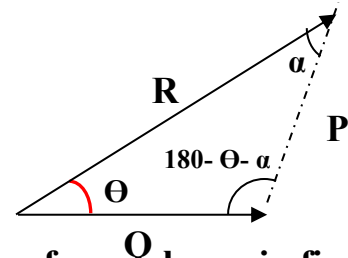

**Example:** Determine the magnitude of resultant for the two forces shown in figure .

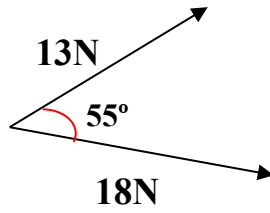

**Solution:**

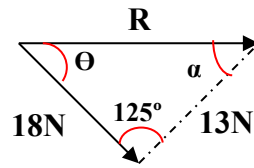
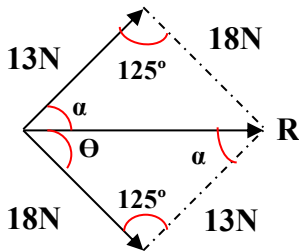

$$180 - \theta - \alpha = 180 - (\theta + \alpha) = 180 - 55 = 125^\circ$$

$$R^2 = P^2 + Q^2 - 2PQ \cos(180 - \theta - \alpha)$$

$$R^2 = (13)^2 + (18)^2 - 2 \times 13 \times 18 \times \cos 125^\circ$$

$$R^2 = 761.43N$$

$$R = 27.59N$$

**Example:** Resolve the (300N) force into two components as shown in figure.

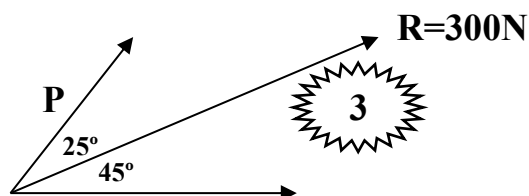

**Solution:**

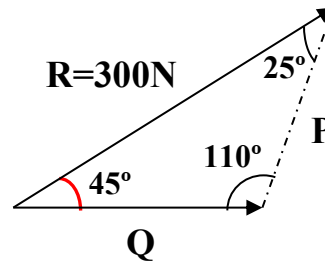
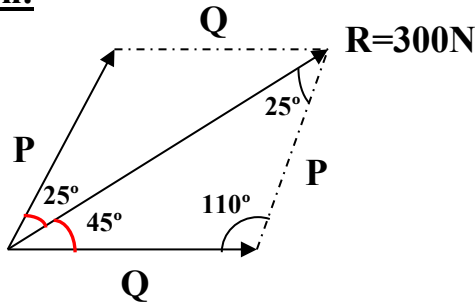

$$(180 - \theta - \alpha) = 180 - 45 - 25 = 110^\circ$$

$$\frac{R}{\sin(180 - \theta - \alpha)} = \frac{P}{\sin\theta} = \frac{Q}{\sin\alpha}$$

$$\frac{300}{\sin 110} = \frac{P}{\sin 45^\circ} = \frac{Q}{\sin 25^\circ}$$

$$\frac{300}{\sin 110} = \frac{P}{\sin 45^\circ}$$

$$300 \sin 45^\circ = P \sin 110^\circ$$

$$P = 225.74 \text{ N}$$

$$\frac{300}{\sin 110} = \frac{Q}{\sin 25^\circ}$$

$$300 \sin 25^\circ = Q \sin 110^\circ$$

$$Q = 134.92 \text{ N}$$

**Example:** Resolve the (1000N) force shown in figure into two Perpendicular components.

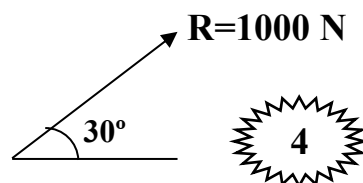

**Solution:**

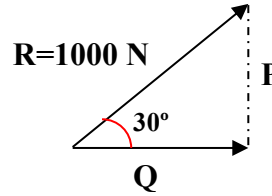
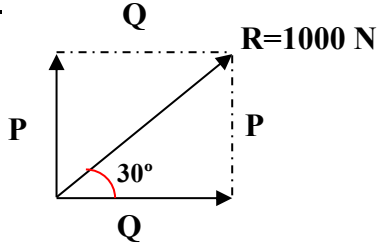

$$\sin 30^\circ = \frac{P}{1000} \quad P = 1000 \sin 30^\circ = 500N$$

$$\cos 30^\circ = \frac{Q}{1000} \quad Q = 1000 \cos 30^\circ = 866N$$

**Example:** Resolve the (390N) force shown in figure into two Perpendiculars components.

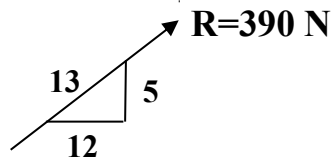

**Solution**

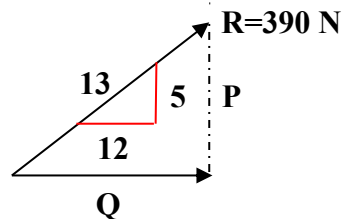
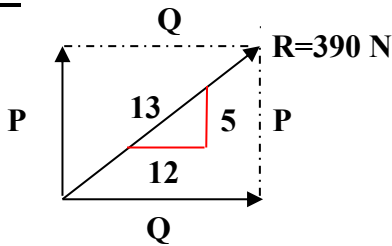

$$\frac{5}{13} = \frac{P}{390} \quad \Rightarrow \quad P = 150N$$

$$Q = 360N \quad \Rightarrow \quad \frac{12}{13} = \frac{Q}{390}$$

**Example:** Resolve the (600N) force shown in figure into two components one of them perpendicular on the inclined surface and the another parallel to it.

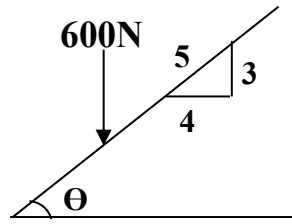

**Solution:**

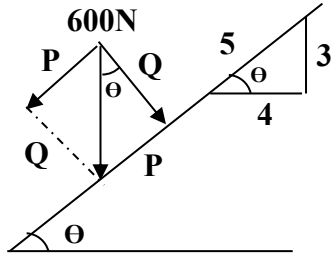

$$\frac{3}{5} = \frac{P}{600} \quad \Rightarrow \quad 3 \times 600 = 5 \times P \quad \Rightarrow \quad P = 360N$$

$$\frac{4}{5} = \frac{Q}{600} \quad \Rightarrow \quad 4 \times 600 = 5 \times Q \quad \Rightarrow \quad Q = 480N$$

**Moment of Force** : Is a measure to its tendency to turn a force about a point or axis.

**Mathematical expression of moment:**

$$Ma = F \cdot d$$

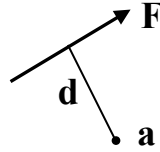

**F = the magnitude of force.**

**d = moment arm = the perpendicular distance between the force and the point.**

**Direction of Moment:**

Clock wise - 

Counter clockwise + 

**Units of Moment: N.cm, N.m, KN.m, Ib.in .**

**Varignon's Theory: the moment of a force about any point or axis is equal to the vector sum of the moments of its components about the same point or axis .**

**Example: Determine the moment of the (100N) force shown in figure about the axis through point A , if (r=50cm).**

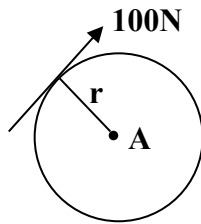

**Solution:**

$$\begin{aligned}
 &+ \text{ (counter-clockwise arrow) } Ma = F \cdot d \\
 &= - 100 \times 50 = - 5000 \text{ N.cm} = 5000 \text{ N.cm} \text{ (clockwise arrow)}
 \end{aligned}$$

**Example: Determine the moment of the (130N) force shown in figure about the axis through point A .**

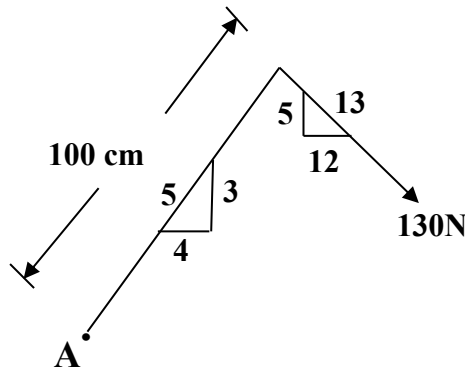

**Solution:**

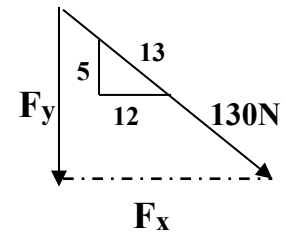
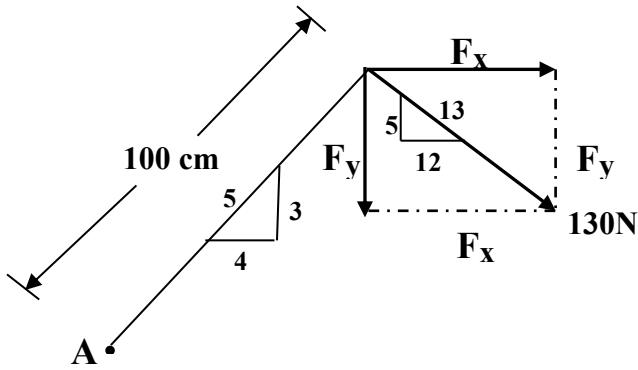

$$\frac{F_x}{130} = \frac{12}{13}$$

$$F_x \times 13 = 130 \times 12 \quad \Rightarrow \quad F_x = \frac{130 \times 12}{13} = 120\text{N}$$

$$\frac{F_y}{130} = \frac{5}{13}$$

$$F_y \times 13 = 130 \times 5 \quad \Rightarrow \quad F_y = \frac{130 \times 5}{13} = 50\text{N}$$

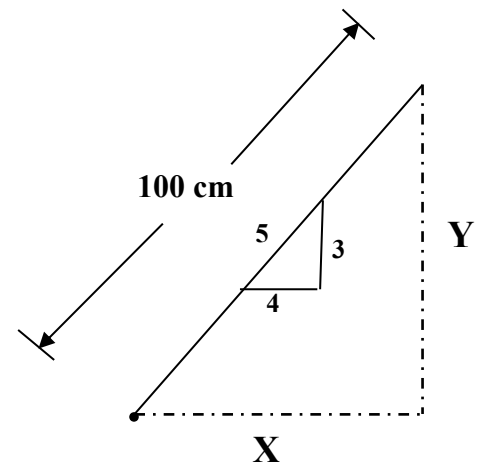
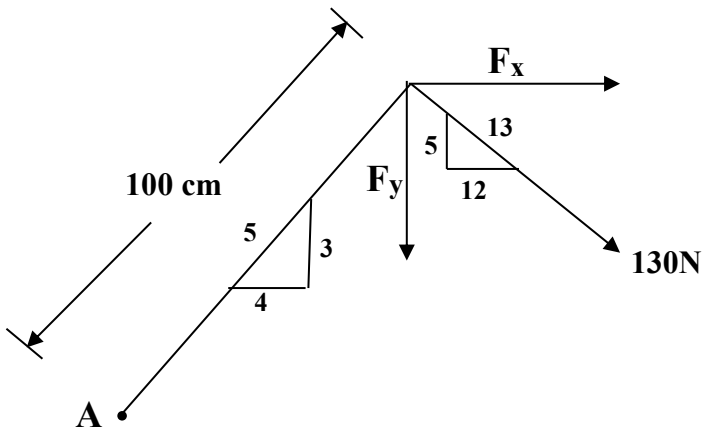

$$\frac{X}{100} = \frac{4}{5} \quad \Rightarrow \quad 5X = 400 \quad \Rightarrow$$

$$X = 80\text{ cm}$$

$$\frac{Y}{100} = \frac{3}{5} \quad \Rightarrow \quad 5Y = 300 \quad \Rightarrow$$

$$Y = 60\text{ cm}$$

$$\begin{aligned}
 + \curvearrowright Ma &= -F_x * Y - F_y * X \\
 &= -120 * 60 - 50 * 80 \\
 &= -11200\text{ N.cm} = 11200\text{ N.cm} \quad \curvearrowright
 \end{aligned}$$

### Couples

A couple consists of two equal forces which have parallel line of actions and opposite senses

and work on turn the body .

Moment of a couple:  $Mc$

$$Mc = F \cdot d$$

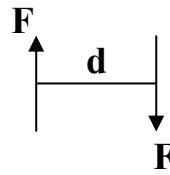

$Mc$ : the sum of the moments of the forces.

$F$  : the magnitude of the force.

$d$  : the perpendicular distance between the forces .

Transformation of a couple:

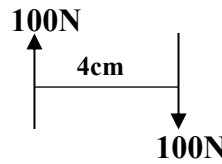
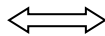
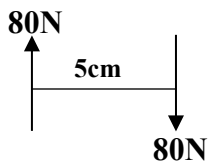

$$+ \curvearrowright Mc = F \cdot d = -80 \times 5 = -400 \text{ N.cm} = 400 \text{ N.cm} \curvearrowleft$$

$$Mc = F \cdot d = -100 \times 4 = -400 \text{ N.cm} = 400 \text{ N.cm} \curvearrowleft$$

***NOTE: the moment of a couple about any point is equal.***

Example: Determine the moment of the couple shown in figure about the axis through points A, B, D.

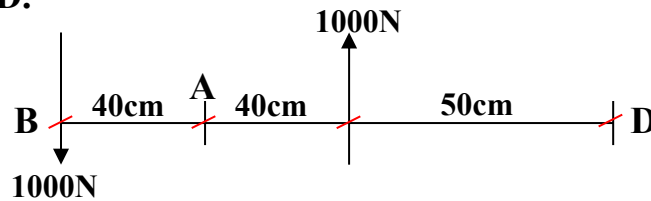

Solution:

$$+ \curvearrowright Mc_{(A)} = 1000 \times 40 + 1000 \times 40 = 80000 \text{ N.cm}$$

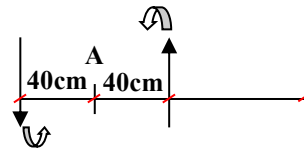

$$+ \curvearrowright Mc_{(B)} = 1000 \times (40 + 40) = 80000 \text{ N.cm}$$

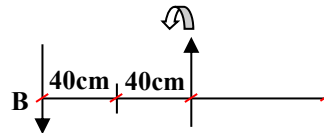

$$+ \curvearrowright Mc_{(D)} = 1000 \times (40 + 40 + 50) - 1000 \times 50 = 80000 \text{ N.cm}$$

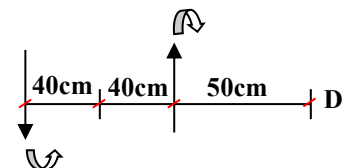

**NOTE:** two or more couples may be replaced by a single couple have the same magnitude and direction of moment results by the summation of moments of the original couples .

**Example:** Replace the following couples shown in figure by a single couple its forces effects horizontally at points B, D.

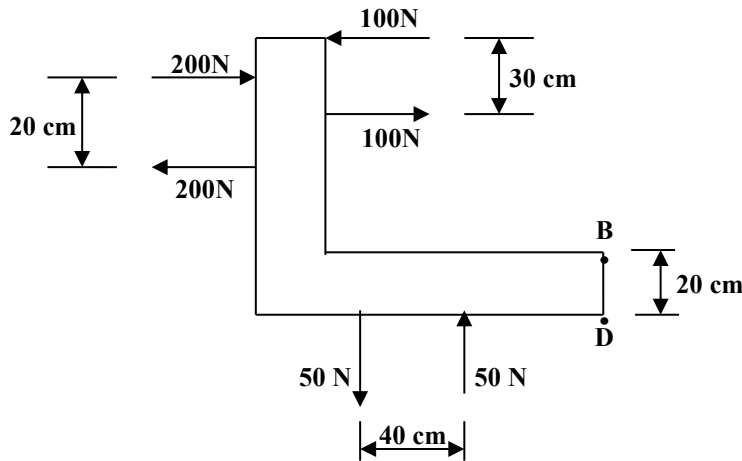

**Solution:**

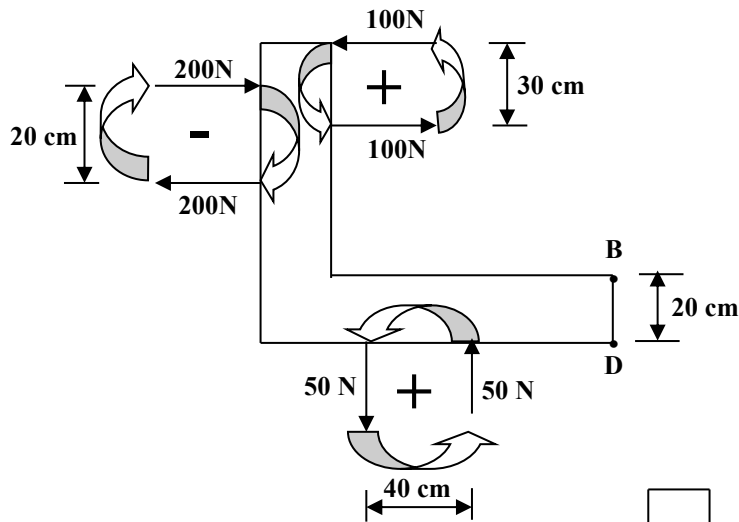

$$+ \curvearrowright Mc = 100 \times 30 + 50 \times 40 - 200 \times 20 = 1000 \text{ N.cm}$$

$$Mc = F.d$$

$$1000 = F \times 20$$

$$F = 50 \text{ N}$$

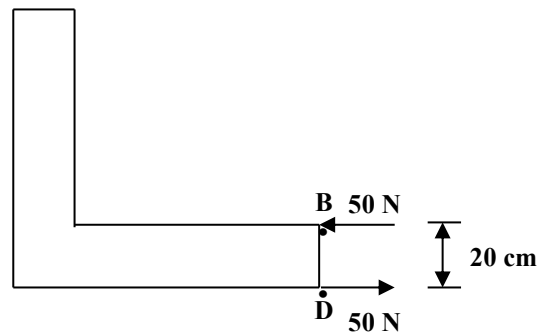

**Resolution of a force into a force and a couple :**

A force can be replaced by a parallel force at any different point and a couple by addition of two equal collinear forces of opposite senses to the force system.

**Example:** Replace the (70N) force shown in figure by a force which acts at point (A) and a couple whose forces act vertically at points (B, D).

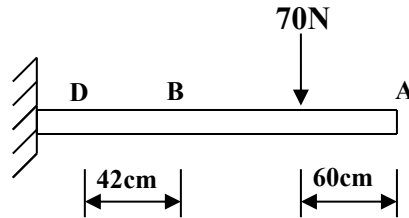

**Solution:**

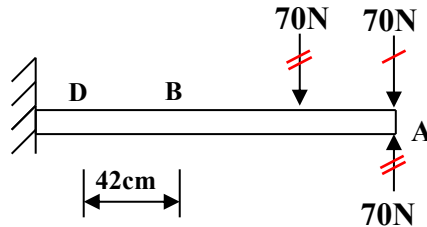

$$+ \curvearrowright Mc = F \cdot d = 70 \times 60 = 4200 \text{ N.cm}$$

$$Mc = F \cdot d$$

$$4200 = F \times 42 \quad \Rightarrow \quad F = \frac{4200}{42} = 100 \text{ N}$$

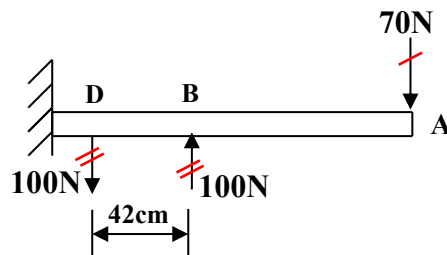

**Resultant:** the resultant is the simplest force which can replace the

original force system without changing its external effect on the body.

If  $R = 0$  the body is in equilibrium.

If  $R \neq 0$  the body will be accelerated.

①: Resultant of concurrent forces : expected resultant is a force.

Example: Determine the magnitude and direction of the resultant for the force system shown in figure.

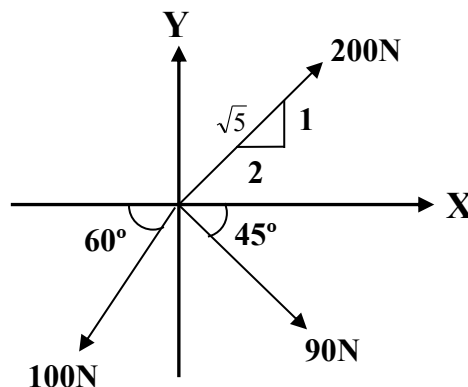

Solution:

$$\begin{aligned}
 + \rightarrow R_x &= 200 \times \frac{2}{\sqrt{5}} + 90 \cos 45 - 100 \cos 60 \\
 &= 178.88 + 63.63 - 50 \\
 &= 192.51 \text{ N} \rightarrow
 \end{aligned}$$

$$\begin{aligned}
 + \uparrow R_y &= 200 \times \frac{1}{\sqrt{5}} - 90 \sin 45 - 100 \sin 60 \\
 &= 89.44 - 63.63 - 86.6 \\
 &= -60.79 \text{ N} = 60.79 \text{ N} \downarrow
 \end{aligned}$$

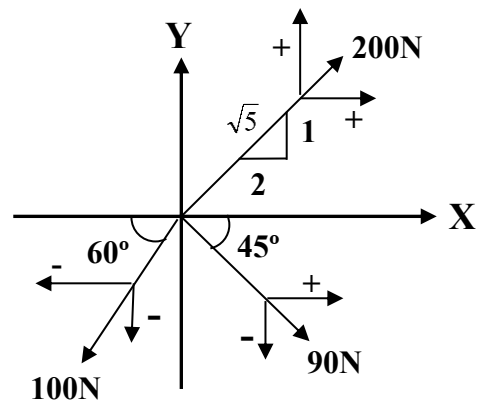

$$R = \sqrt{R_x^2 + R_y^2}$$

$$\begin{aligned}
 R &= \sqrt{(192.51)^2 + (60.79)^2} \\
 &= 201.87 \text{ N}
 \end{aligned}$$

$$\tan \theta = \frac{R_y}{R_x} = \frac{60.79}{192.51} = 0.315$$

$$\theta = \tan^{-1} 0.315 = 17.5^\circ$$

Example: Determine the magnitude and direction of the resultant for the force system shown

in figure.

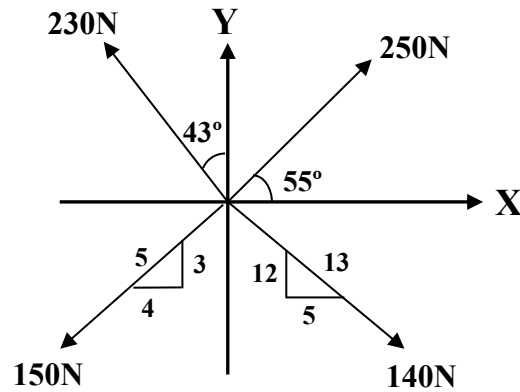

**Solution:**

$$\begin{aligned}
 + \rightarrow R_x &= 250 \cos 55^\circ + 140 \times \frac{5}{13} - 150 \times \frac{4}{5} - 230 \sin 43^\circ \\
 &= 143.39 + 53.84 - 120 - 156.85 \\
 &= -79.62N = 79.62N \leftarrow
 \end{aligned}$$

$$\begin{aligned}
 + \uparrow R_y &= 250 \sin 55^\circ - 140 \times \frac{12}{13} - 150 \times \frac{3}{5} + 230 \cos 43^\circ \\
 &= 204.78 - 129.23 - 90 + 168.21 \\
 &= 153.76N
 \end{aligned}$$

$$R = \sqrt{R_x^2 + R_y^2}$$

$$R = \sqrt{(79.62)^2 + (153.76)^2}$$

$$= 173.16N$$

$$\tan \theta = \frac{R_y}{R_x} = \frac{153.76}{79.62} = 1.931$$

$$\theta = \tan^{-1} 1.931 = 62.62^\circ$$

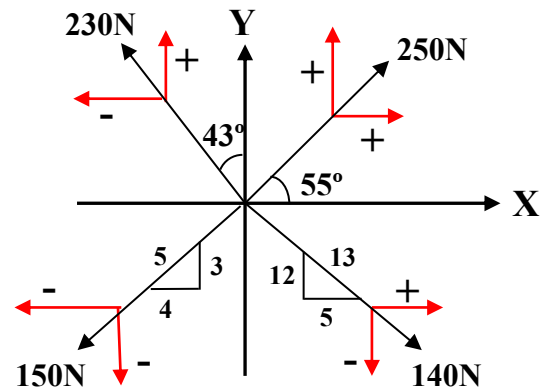

② : **Resultant of non-concurrent, non-parallel forces:**

If  $R \neq 0$  the resultant is a force

If  $R = 0$  the resultant is a couple and  $M_c = \sum M_o$

**Example:** Determine the resultant of the forces and the couple shown in figure and locate

it with respect to point (A).

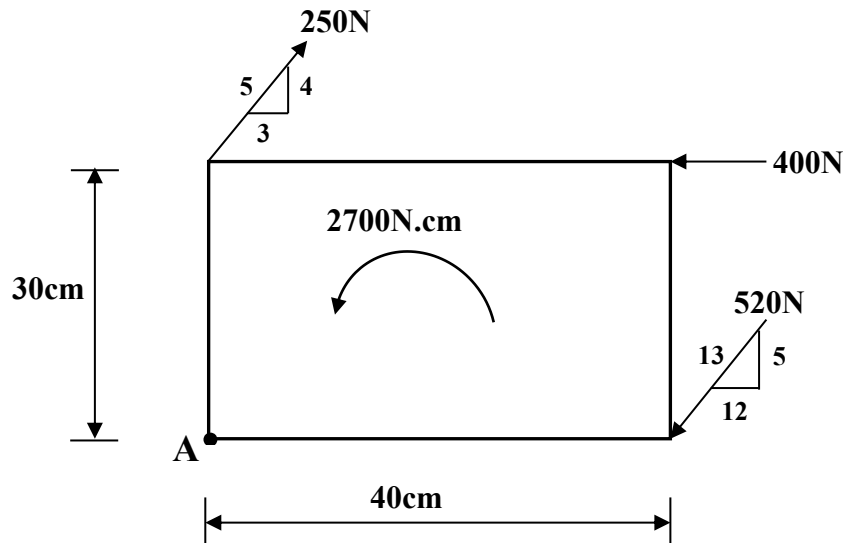

**Solution:**

$$+ \rightarrow R_x = 250 \times \frac{3}{5} - 520 \times \frac{12}{13} - 400$$

$$= -730N = 730N \leftarrow$$

$$+ \uparrow R_y = 250 \times \frac{4}{5} - 520 \times \frac{5}{13} = 0$$

$$R = \sqrt{(R_x)^2 + (R_y)^2}$$

$$= \sqrt{(730)^2 + (0)^2} = 730N$$

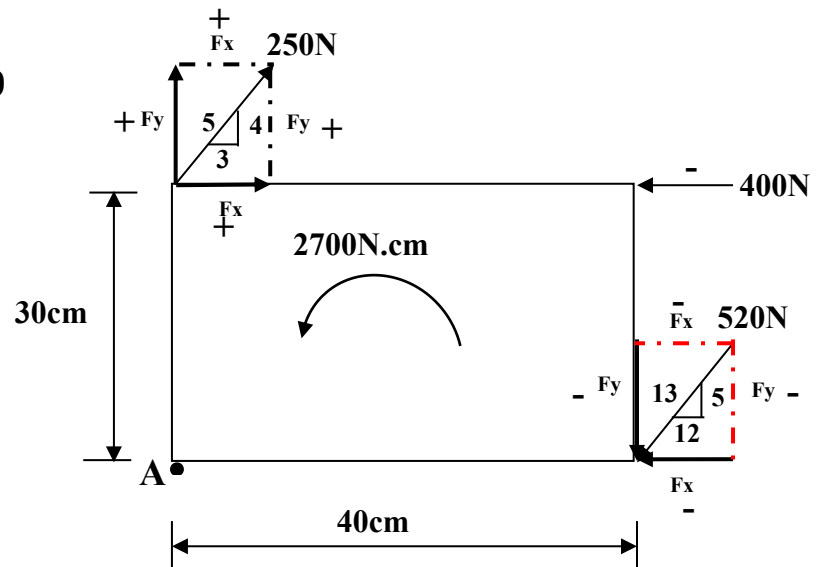

$$R \times d = \sum MA$$

$$730 \times d = 400 \times 30 + 2700 - 250 \times \frac{3}{5} \times 30 - 520 \times \frac{5}{13} \times 40$$

$$730 \times d = 12000 + 2700 - 4500 - 8000$$

$$730 \times d = 2200$$

$$d = \frac{2200}{730} = 3.01cm$$

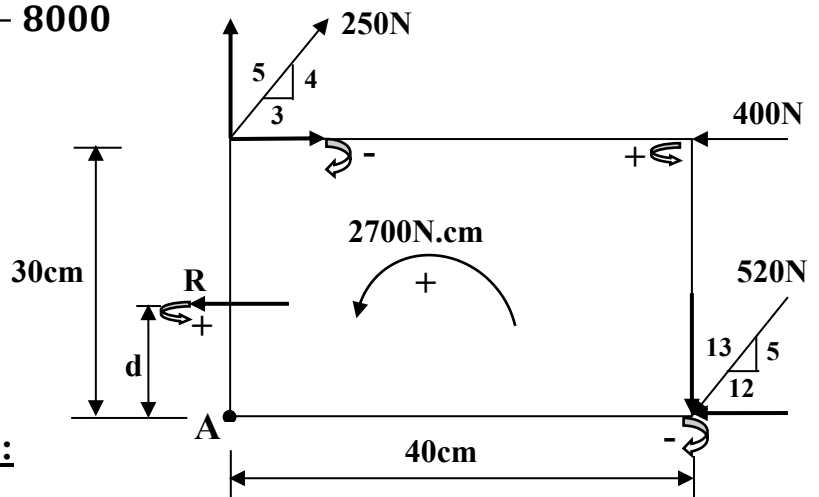

**3): Resultant of parallel force system:**

If  $R \neq 0$  then the resultant is a force

If  $R = 0$  then the resultant is a couple and  $M_c = \sum Ma$

**Example:** Determine the resultant of the parallel forces shown in figure, and its location from point ( a ).

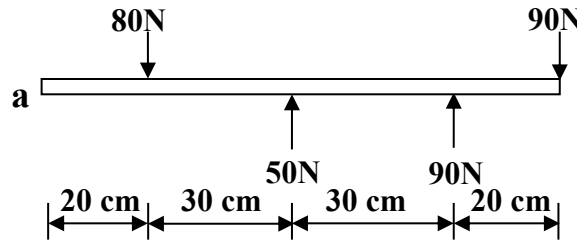

**Solution:**

$$\begin{aligned}
 + \uparrow R &= \sum Fy \\
 &= 50 + 90 - 80 - 90 \\
 &= -30N = 30N \downarrow
 \end{aligned}$$

$$\begin{aligned}
 + \curvearrowright R \times d &= \sum Ma \\
 -30 \times d &= 50 \times 50 + 90 \times 80 - 80 \times 20 - 90 \times 100 \\
 -30 \times d &= 2500 + 7200 - 1600 - 9000 \\
 -30 \times d &= -900 \\
 d &= \frac{-900}{-30} = 30cm
 \end{aligned}$$

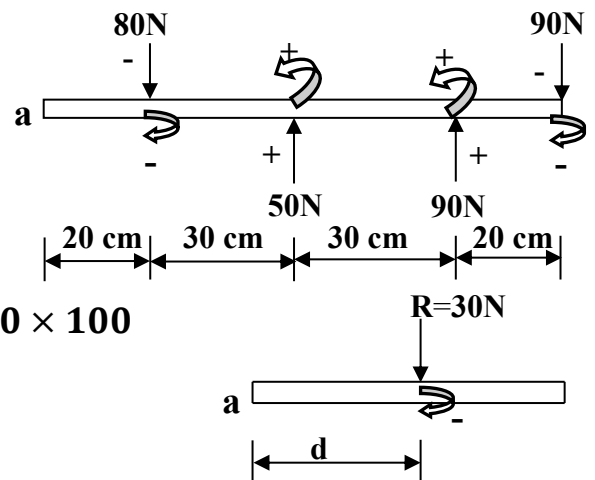

**Example:** Determine the resultant of the parallel forces shown in figure, and its location from point ( a ).

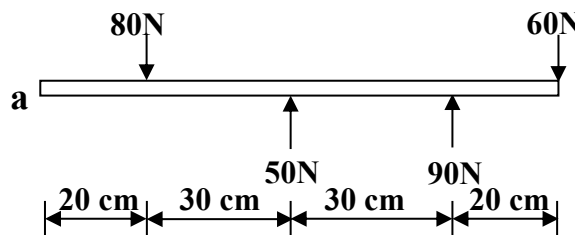

**Solution:**

$$\begin{aligned}
 + \uparrow R &= \sum Fy \\
 &= 50 + 90 - 80 - 60 = 0
 \end{aligned}$$

The resultant may be a couple

$$\begin{aligned}
 + \curvearrowright M_c &= \sum Ma \\
 &= 50 \times 50 + 90 \times 80 - 80 \times 20 - 60 \times 100 = 2100N.cm
 \end{aligned}$$

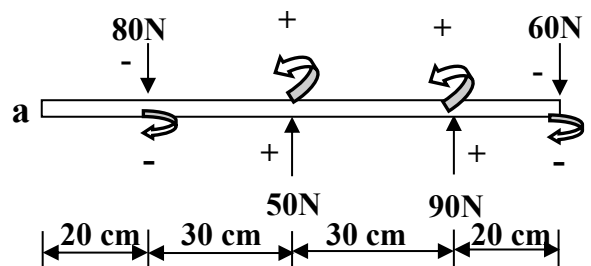

**DISTRIBUTED LOADS:**

① : Uniformly Distributed Loads or rectangular loads

$$R = \frac{W}{u.l} \times L$$

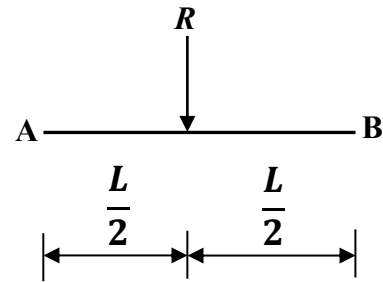
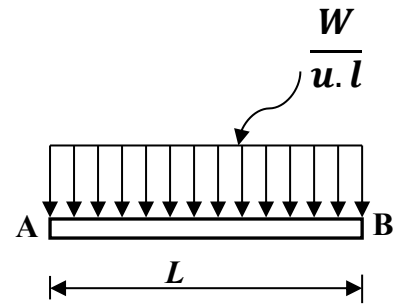

**R:** resultant of the total weight of construction

$\frac{W}{u.l}$ : the weight for unit length

**L:** the length of construction

**NOTE:** the location of (**R**) is in the middle  
i.e.  $\frac{L}{2}$  from A and B

② : Varying Loads or triangular loads

$$R = \frac{1}{2} \times W \times L$$

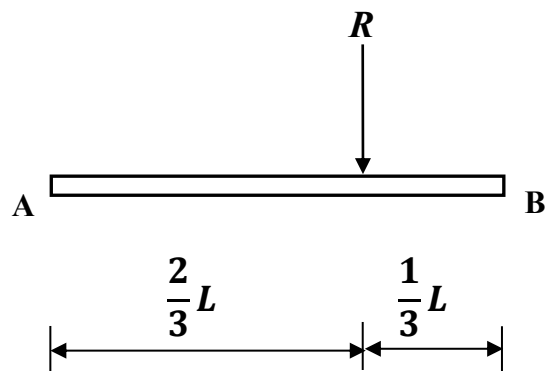
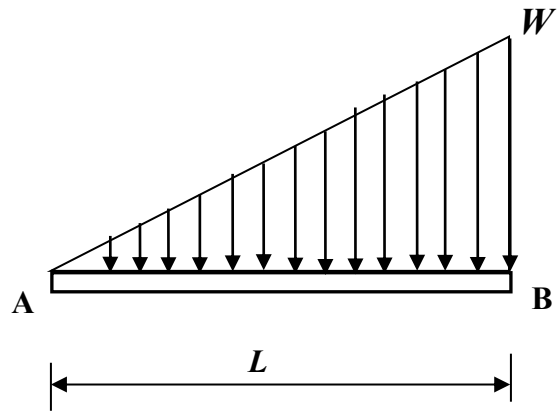

**NOTE:** the location of (**R**) is:

$\frac{1}{3}L$  from point B and

$\frac{2}{3}L$  from point A

**Example:** Determine the resultant of the distributed load shown in figure and indicate its

location from point (A) .

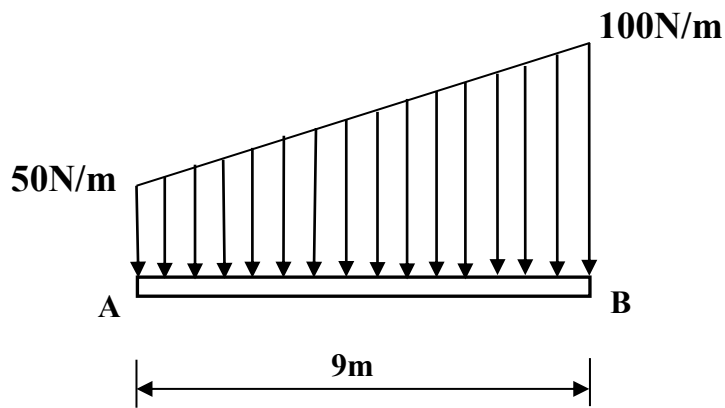

**Solution:**

$$+\uparrow R1 = -(9 \times 50) = -450N = 450N \downarrow$$

$$+\uparrow R2 = -\left(\frac{1}{2} \times 9 \times 50\right) = -225N = 225N \downarrow$$

$$+\uparrow R = \sum Fy = (-450) + (-225) = -675N = 675N \downarrow$$

$$+\curvearrowright R \times d = \sum Ma$$

$$-675 \times d = (-450 \times 4.5) + (-225 \times 6)$$

$$-675 \times d = (-2025) + (-1350)$$

$$-675 \times d = -3375$$

$$d = \frac{-3375}{-675} = 5m$$

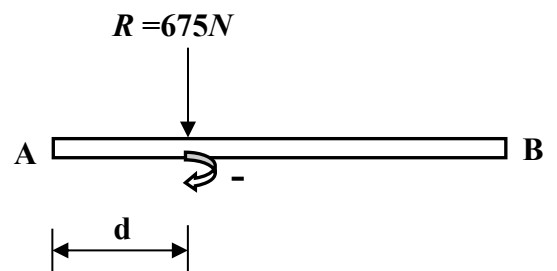
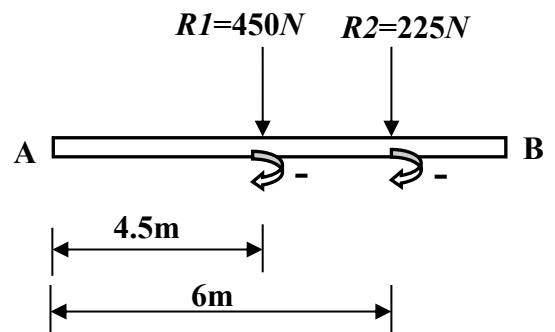
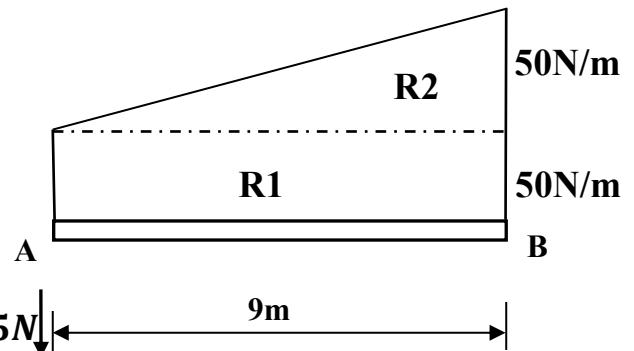



**EQUILIBRIUM**







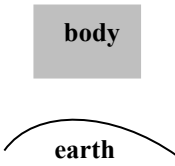
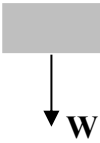

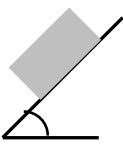
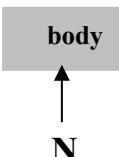
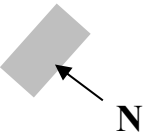
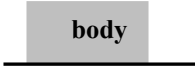
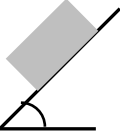
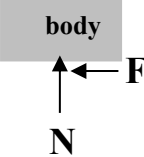
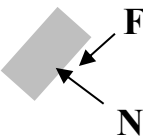
*Is the condition of the body when the resultant of forces acting on it is equal to (ZERO)*

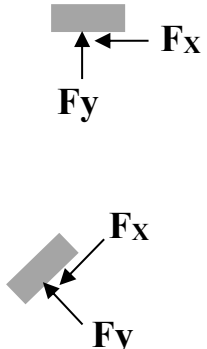
**Free Body Diagram: F.B.D**

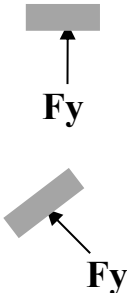
*Is a diagram shown all the forces acting on the body.*

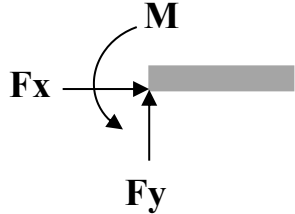
**Types of supports:**

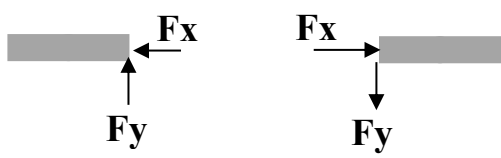
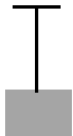
Type of support	Body diagram	F.B.D
1-Earth		
2- Smooth surface	 <p style="text-align: right;"><b>Plane</b></p>  <p style="text-align: right;"><b>Inclined</b></p>	 <p style="text-align: center;"><b>N</b></p>  <p style="text-align: right;"><b>N</b></p>
3-Rough surface	 <p style="text-align: right;"><b>Plane</b></p>  <p style="text-align: right;"><b>Inclined</b></p>	 <p style="text-align: center;"><b>N</b></p> <p style="text-align: right;"><b>F</b></p>  <p style="text-align: right;"><b>N</b></p> <p style="text-align: right;"><b>F</b></p>

<p><b>4-Hinge</b></p>		
<p><b>5-Roller</b></p>		
<p><b>6-Fixed</b></p>		
<p><b>7-Internal hinge</b></p>		
<p><b>8-Cable</b></p>		

①: Equilibrium of concurrent forces:

The resultant of this system is a force can be calculated by:

$$R = \sqrt{R_x^2 + R_y^2}$$

In equilibrium condition  $R=0$  then:

$$R_x = \sum F_x = 0 \quad \dots \dots (1)$$

$$R_y = \sum F_y = 0 \quad \dots \dots (2)$$

Example: Find all forces which effects on the cylinder (A) shown in figure if all concurrent surfaces are smooth, and the weight of cylinder (A) is (500N), and cylinder (B) is (300N) .

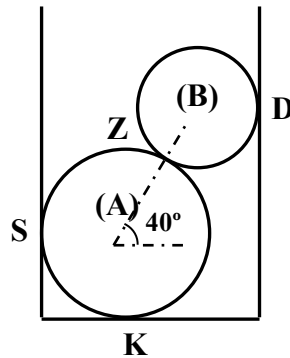

Solution:

From F.B.D of cylinder (B):

$$+\uparrow \sum F_y = 0$$

$$F_Z \sin 40^\circ - 300 = 0$$

$$F_Z = \frac{300}{\sin 40^\circ} = 466.71 \text{ N}$$

From F.B.D of cylinder (A):

$$+\rightarrow \sum F_x = 0$$

$$F_s - 466.71 \cos 40^\circ = 0$$

$$F_s = 466.71 \cos 40^\circ = 357.52 \text{ N}$$

$$+\uparrow \sum F_y = 0$$

$$F_k - 500 - 466.71 \sin 40^\circ = 0$$

$$F_k = 500 + 466.71 \sin 40^\circ = 800 \text{ N}$$

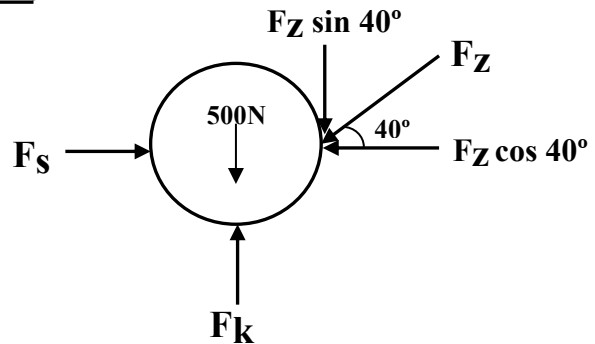

F.B.D of cvlinder (A)

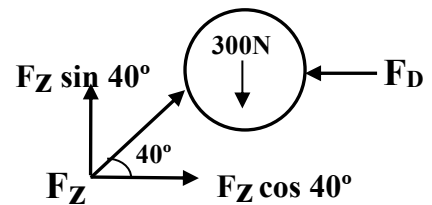

F.B.D of cylinder (B)

**Example:** Determine the forces exerted by the planes (AB) and (BC) on the cylinder shown in figure if the weight of cylinder is (900N) and the surfaces are smooth.

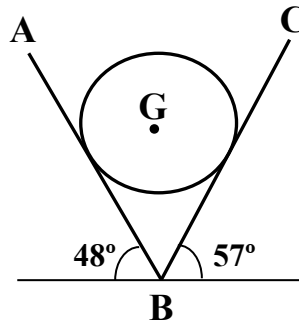

**Solution:**

$$+\rightarrow \sum F_x = 0$$

$$F_{AB} \sin 48^\circ - F_{BC} \sin 57^\circ = 0 \dots\dots\dots (1) \quad \times \cos 57$$

$$+\uparrow \sum F_y = 0$$

$$F_{AB} \cos 48^\circ + F_{BC} \cos 57^\circ - 900 = 0 \dots\dots\dots (2) \quad \times \sin 57$$

$$F_{AB} \sin 48^\circ \cos 57^\circ - F_{BC} \sin 57^\circ \cos 57^\circ = 0 \dots\dots\dots (1)$$

$$F_{AB} \cos 48^\circ \sin 57^\circ + F_{BC} \sin 57^\circ \cos 57^\circ - 900 \sin 57^\circ = 0 \dots\dots\dots (2)$$

$$+ \frac{F_{AB}(\sin 48^\circ \cos 57^\circ + \cos 48^\circ \sin 57^\circ) = 900 \sin 57^\circ}{}$$

$$F_{AB} = \frac{900 \sin 57^\circ}{\sin 48^\circ \cos 57^\circ + \cos 48^\circ \sin 57^\circ} = 781.43N$$

Substitute in equation (1) :

$$781.43 \sin 48 - F_{BC} \sin 57 = 0$$

$$781.43 \sin 48 = F_{BC} \sin 57$$

$$F_{BC} = \frac{781.43 \sin 48}{\sin 57} = 692.42$$

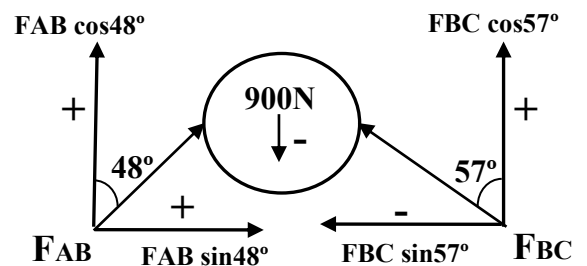

F.B.D of cylinder

② : Equilibrium of non concurrent forces:

The resultant of this system is:

A force can be calculated by  $R = \sqrt{R_x^2 + R_y^2}$  when  $R \neq 0$

OR A couple can be calculated by  $M_c = \sum M$  when  $R = 0$

In equilibrium condition  $R=0$  and  $M_c=0$  then:

$R_x = \sum F_x = 0$  .....(1)

$R_y = \sum F_y = 0$  .....(2)

$M_c = \sum M = 0$  .....(3)

Example: Determine the reactions at supports (A) and (B) for the beam loaded as shown in figure .

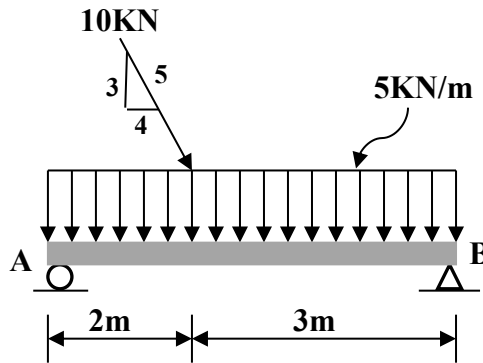

Solution:

$+ \uparrow R = - (5 \times 5) = - 25 \text{ kN} = 25 \text{ kN} \downarrow$

$+ \rightarrow F_x = 10 \times \frac{4}{5} = 8 \text{ kN}$

$+ \uparrow F_y = - (10 \times \frac{3}{5}) = - 6 \text{ kN} = 6 \text{ kN} \downarrow$

$+ \rightarrow \sum F_x = 0$

$8 - B_x = 0 \Rightarrow B_x = 8 \text{ kN}$

$+ \curvearrowleft \sum M_A = 0$

$B_y \times 5 - 6 \times 2 - 25 \times 2.5 = 0 \Rightarrow B_y = 14.9 \text{ kN}$

$+ \uparrow \sum F_y = 0$

$A_y + 14.9 - 25 - 6 = 0 \Rightarrow A_y = 16.1 \text{ kN}$

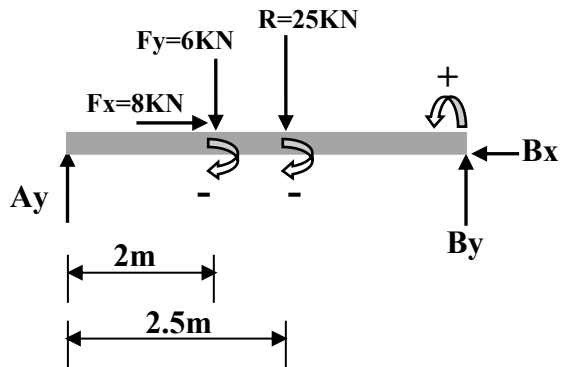
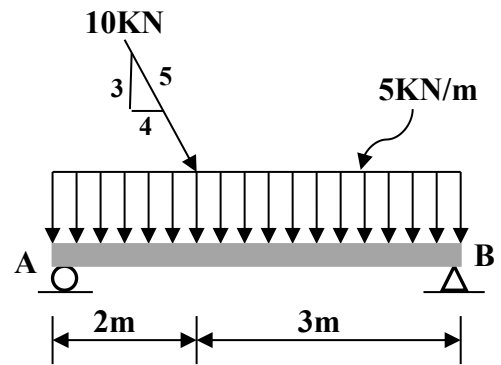

F.B.D of the beam

**Example:** Determine the reactions at supports (A) and (B) for the beam loaded as shown in figure .

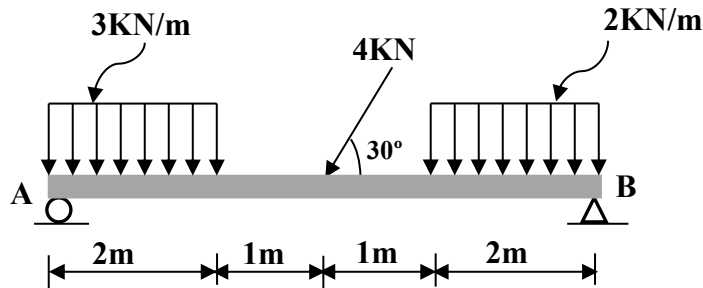

**Solution:**

$$\begin{aligned}
 + \uparrow R_1 &= - (3 \times 2) = - 6 \text{ kN} = 6 \text{ kN} \downarrow \\
 + \uparrow R_2 &= - (2 \times 2) = - 4 \text{ kN} = 4 \text{ kN} \downarrow \\
 + \rightarrow F_x &= -4 \cos 30 = -3.46 \text{ kN} = 3.46 \text{ kN} \leftarrow \\
 + \uparrow F_y &= -4 \sin 30 = -2 \text{ kN} = 2 \text{ kN} \downarrow
 \end{aligned}$$

$$+ \rightarrow \sum F_x = 0$$

$$B_x - 3.46 = 0 \quad \Rightarrow \quad B_x = 3.46 \text{ kN}$$

$$+ \curvearrowright \sum M_A = 0$$

$$B_y \times 6 - 4 \times 5 - 2 \times 3 - 6 \times 1 = 0$$

$$B_y \times 6 - 20 - 6 - 6 = 0$$

$$B_y \times 6 = 32 \quad \Rightarrow \quad B_y = 5.33 \text{ kN}$$

$$+ \uparrow \sum F_y = 0$$

$$A_y + 5.33 - 6 - 2 - 4 = 0 \quad \Rightarrow \quad A_y = 6.67 \text{ kN}$$

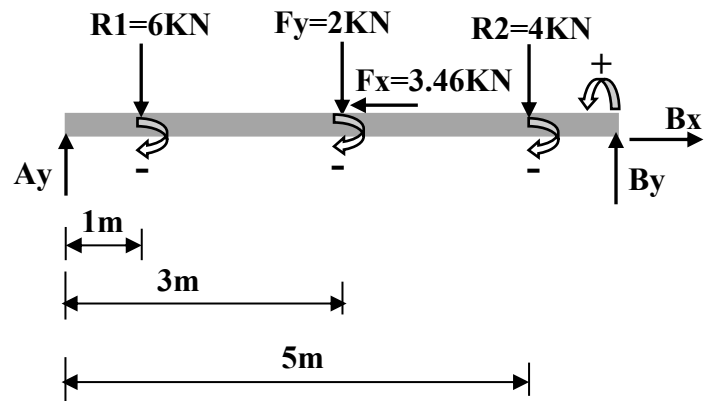
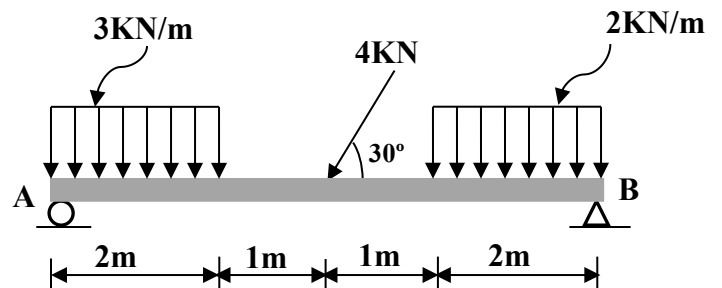

F.B.D of the beam

**Example:** Determine the reactions at supports (A) and (B) for the beam loaded as shown in figure .

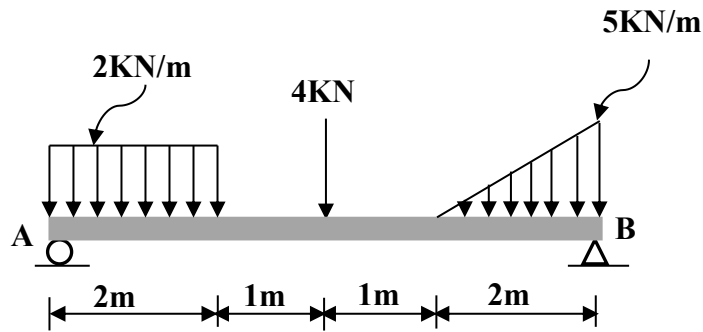

**Solution:**

$$+ \uparrow R_1 = - (2 \times 2) = - 4 \text{ kN} = 4 \text{ kN} \downarrow$$

$$+ \uparrow R_2 = - (1/2 \times 5 \times 2) = - 5 \text{ kN} = 5 \text{ kN} \downarrow$$

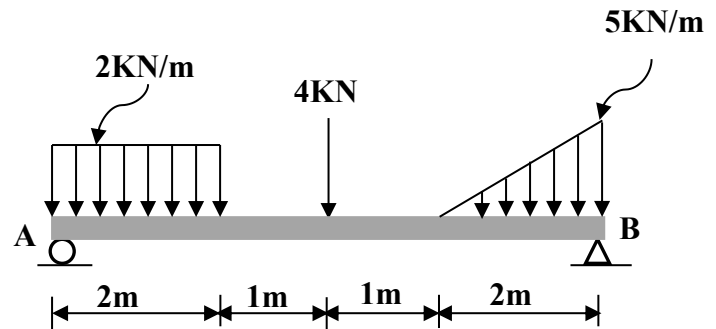

$$+ \rightarrow \sum F_x = 0 \quad \Rightarrow \quad B_x = 0$$

$$+ \curvearrowright \sum M_A = 0$$

$$B_y \times 6 - 5 \times 5.33 - 4 \times 3 - 4 \times 1 = 0$$

$$B_y \times 6 - 26.65 - 12 - 4 = 0$$

$$B_y \times 6 = 42.65 \quad \Rightarrow \quad B_y = 7.11 \text{ kN}$$

$$+ \uparrow \sum F_y = 0$$

$$A_y + 7.11 - 4 - 4 - 5 = 0 \quad \Rightarrow \quad A_y = 5.89 \text{ kN}$$

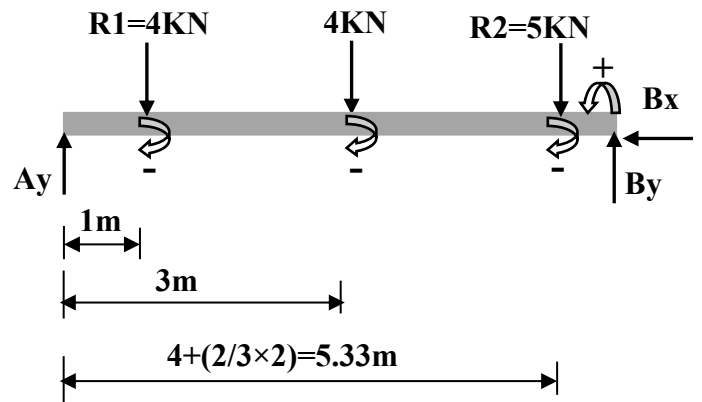

**F.B.D of the beam**

**Example:** Determine the reactions at support (A) for the beam loaded as shown in figure .

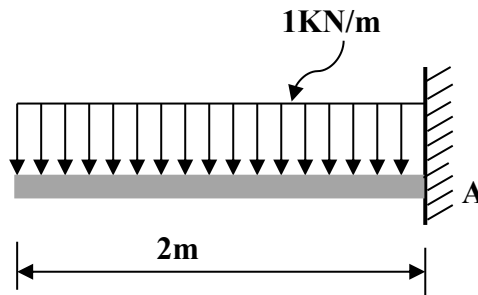

**Solution:**

$$+ \uparrow R = - (2 \times 1) = - 2 \text{ kN} = 2 \text{ kN} \downarrow$$

$$+ \rightarrow \sum F_x = 0 \quad \Rightarrow \quad A_x = 0$$

$$+ \uparrow \sum F_y = 0$$

$$A_y - 2 = 0 \quad \Rightarrow \quad A_y = 2 \text{ kN}$$

$$+ \curvearrowright \sum M_A = 0$$

$$2 \times 1 - M_A = 0 \quad \Rightarrow \quad M_A = 2 \text{ kN}\cdot\text{m}$$

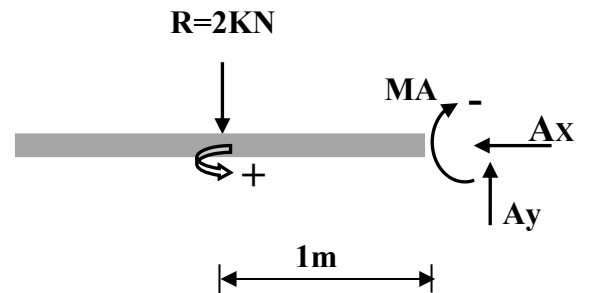
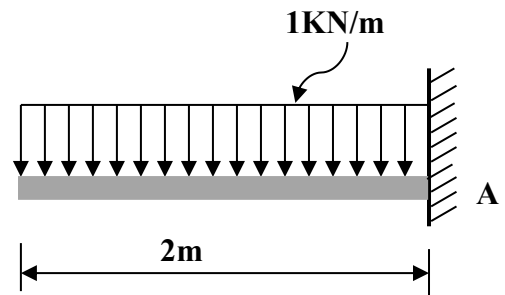

**F.B.D of the beam**

## TRUSSES:

A truss is a structure composed of a number of members joined together at their ends to form a rigid body .

Analysis of trusses: is how to determine the forces in each member of the truss.

- ①: Method of joints : In this method a single joint is isolated as a free body diagram and applying the equations of concurrent forces.

$$\sum F_x=0 \quad , \quad \sum F_y=0$$

Example: By using method of joints, Determine the forces in members (AB , AC , BC , BD) of the truss shown in figure and indicate if the member is in tension or compression ( $A_y = E_y = 650\text{N}$ ).

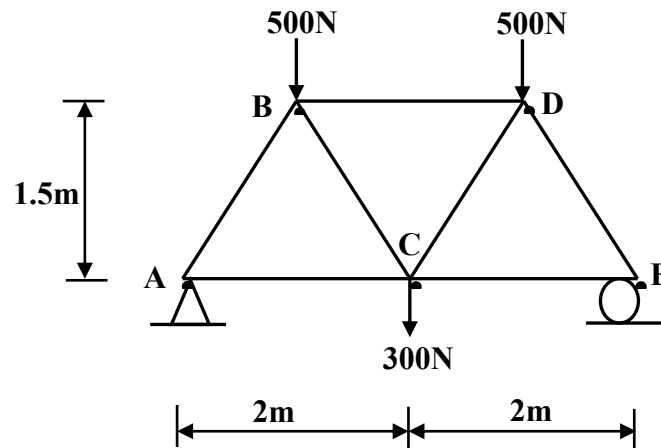

Solution:

Joint (A) :

$$+\uparrow \sum F_y=0$$

$$650 + F_{AB} \times 1.5 / 1.8 = 0$$

$$F_{AB} = -780\text{N} = 780\text{N (C)}$$

$$+\rightarrow \sum F_x=0$$

$$F_{AC} - 780 \times 1 / 1.8 = 0$$

$$F_{AC} = 433.3\text{N (T)}$$

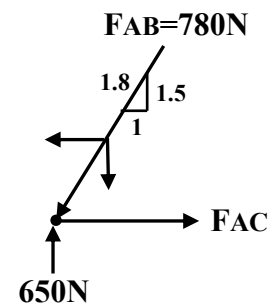
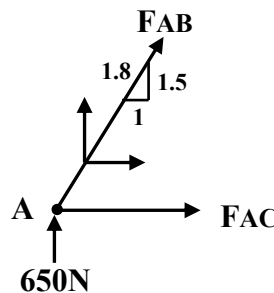

**Joint (B) :**

$$+\uparrow \sum F_y = 0$$

$$780 \times 1.5 / 1.8 - 500 - F_{BC} \times 1.5 / 1.8 = 0$$

$$F_{BC} = 180 \text{ N (T)}$$

$$+\rightarrow \sum F_x = 0$$

$$780 \times 1 / 1.8 + F_{BD} + 180 \times 1 / 1.8 = 0$$

$$F_{BD} = -533.3 \text{ N} = 533.3 \text{ N (C)}$$

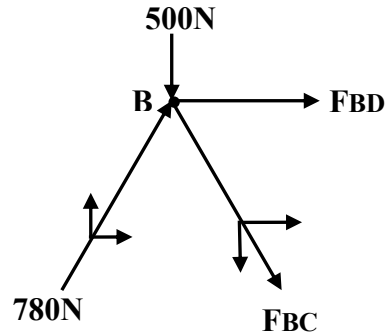

**Example:** By using method of joints, Determine the forces in members (PG, HP, PE) for the truss shown in figure and indicate if the members are in tension or compression.

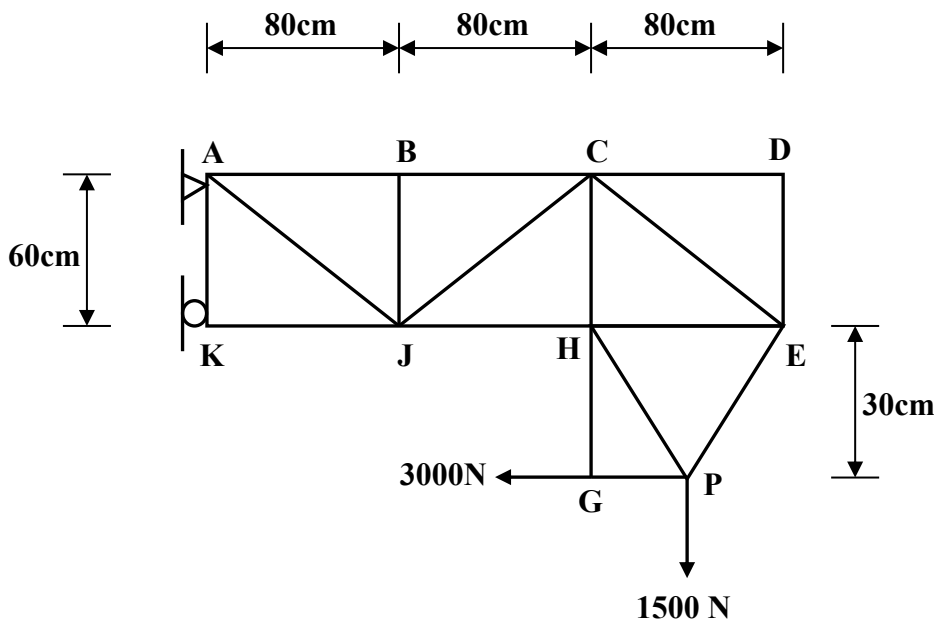

**Solution:**

**Joint (G) :**

$$+\rightarrow \sum F_x = 0$$

$$G_P - 3000 = 0$$

$$G_P = 3000 \text{ N (T)}$$

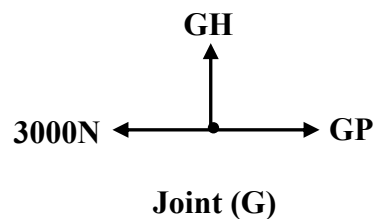

**Joint(P) :**

$\rightarrow \sum F_x = 0$

$PE * \frac{4}{5} - PH * \frac{4}{5} - 3000 = 0 \quad \text{----- (1) } \times 3$

$\uparrow \sum F_y = 0$

$PE * \frac{3}{5} + PH * \frac{3}{5} - 1500 = 0 \quad \text{----- (2) } \times 4$

$PE * \frac{12}{5} - PH * \frac{12}{5} - 9000 = 0 \quad \text{----- (1)}$

$PE * \frac{12}{5} + PH * \frac{12}{5} - 6000 = 0 \quad \text{----- (2)}$

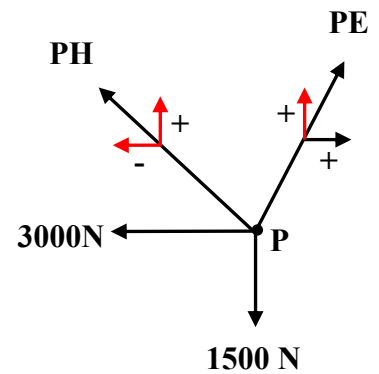

Joint (P)

+

$PE * \frac{24}{5} = 15000$

$PE = 3125 N(T)$

**Sub. In equation (1)**

$3125 * \frac{4}{5} - PH * \frac{4}{5} - 3000 = 0$

$PH = -625 N = 625 N(C)$

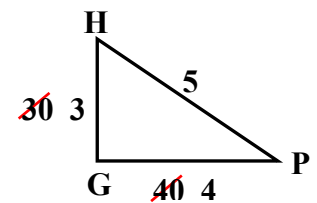
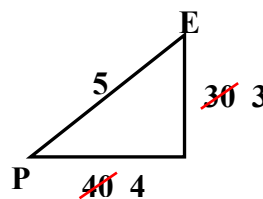

②: **Method of Sections** : When two or more joints are isolated and applying the equations of non-concurrent forces

$\sum F_x = 0 \quad , \quad \sum F_y = 0 \quad , \quad \sum M = 0.$

**Example:** Determine the forces in members ( CK, BK, BJ ) for the truss shown in figure and indicate if the members are in tension or compression if (Ay=400N) and (Ey=500N).

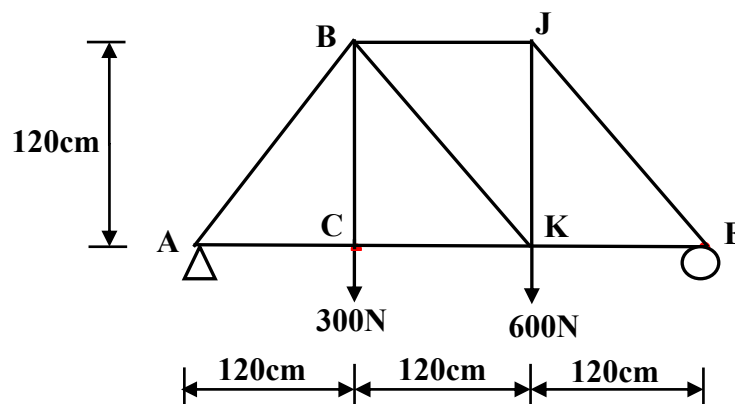

**Solution:**

**From Section (a-a):**

$$+\uparrow \sum F_y = 0$$

$$400 - 300 - BK \times 1 / \sqrt{2} = 0$$

$$BK = 141.4 \text{ N (T)}$$

$$+\curvearrowleft \sum M_B = 0$$

$$CK \times 120 - 400 \times 120 = 0$$

$$CK = 400 \text{ N (T)}$$

$$+\rightarrow \sum F_x = 0$$

$$400 + BJ + 141.4 \times 1 / \sqrt{2} = 0$$

$$BJ = -500 \text{ N} = 500 \text{ N (C)}$$

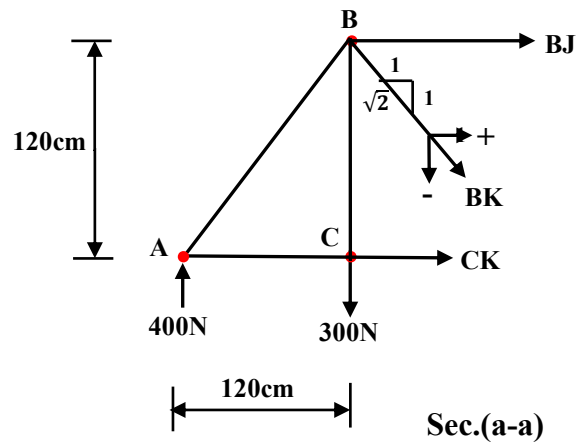
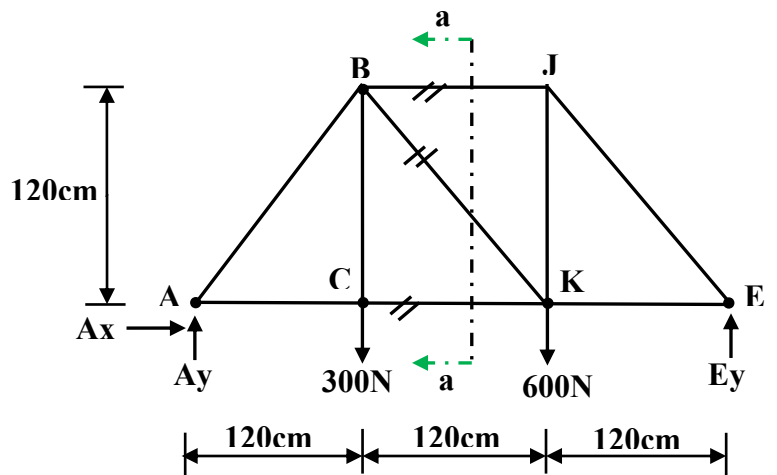

**Example:** By using method of sections, Determine the forces in members (BC, CJ, HJ) for the truss shown in figure and indicate if the members are in tension or compression.

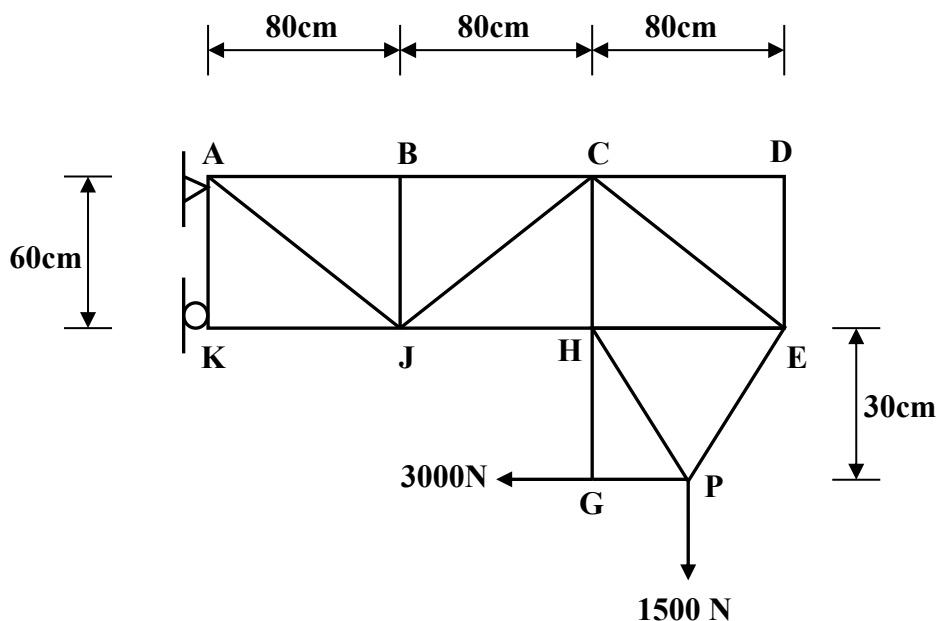

**Solution:**

**From section (1-1) :**

$$+ \uparrow \sum F_y = 0$$

$$- CJ * \frac{3}{5} - 1500 = 0$$

$$CJ = -2500 \text{ N} = 2500 \text{ N}(C)$$

$$+ \curvearrowleft \sum M_J = 0$$

$$-1500 * 120 - 3000 * 30 + BC * 60 = 0$$

$$BC = 4500 \text{ N}(T)$$

$$+ \rightarrow \sum F_x = 0$$

$$-4500 + 2500 * \frac{4}{5} - HJ - 3000 = 0$$

$$HJ = -5500 \text{ N} = 5500 \text{ N}(C)$$

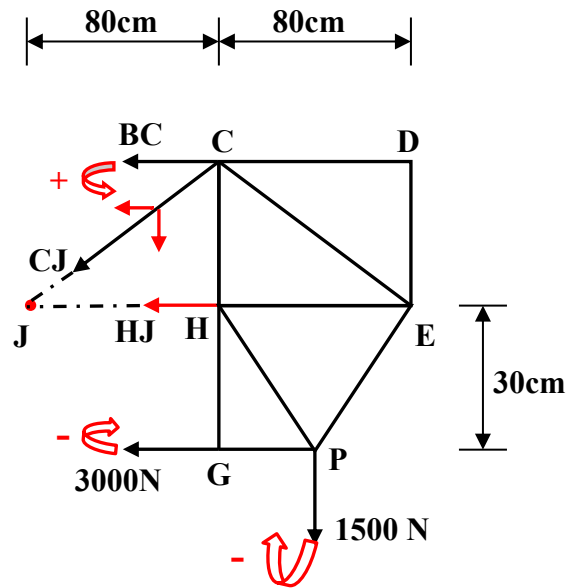
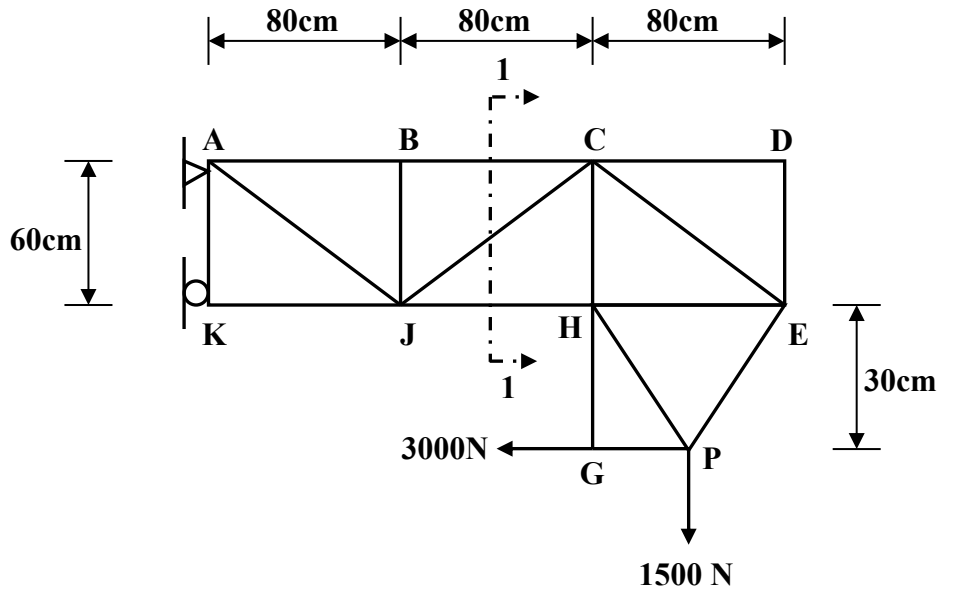
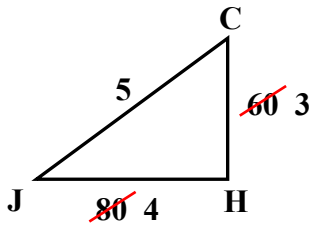

**FRICTION**: Is the force tangent to the contact surface which resists the motion when a body slides or tends to slides on another body .

**Friction Theory**: Let a block of weight (W) rests on a horizontal plane as shown in (Figure 1), and a horizontal force (P) is applied on it as shown in (Figure 2):

1:-When (P=0) the frictional force (F=0) and the block is in equilibrium.



Figure 1

2:-When (P) increased the frictional force (F) is also increased in the same value to prevent motion.

3:-When (F) reach its maximum value (Fmax.) any increase in (P) will cause motion.

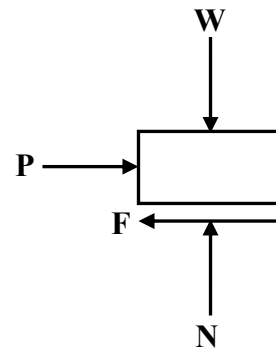

Figure 2

**Laws of friction**: The maximum frictional force (Fmax.) is proportional with the normal force (N) between the contact surfaces .

$$F_{max.} \propto N$$

$$\boxed{F_{max.} = \mu \times N} \implies \mu = F_{max.} / N$$

$\mu$ : coefficient of friction and depends on the roughness of surfaces

**Angle of friction**:

$$\tan \Theta = F_{max.} / N$$

$$\mu = F_{max.} / N$$

$$\boxed{\tan \Theta = \mu}$$

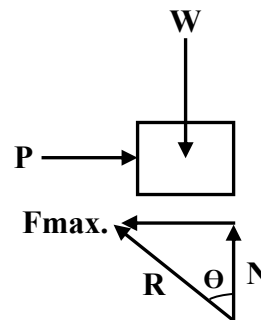

**Example:** Determine the frictional force exerted on the (200N) block weight by the inclined surface shown in figure if the block is subjected to (70N) force, ( $\mu=0.2$ ).

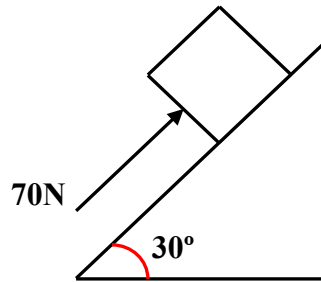

**Solution:**

$$W_x = 200 \times \sin 30 = 100\text{N}$$

$$W_y = 200 \times \cos 30 = 173.2\text{N}$$

Assume the block will move upward

$$\begin{aligned}
 + \nearrow \sum F_x &= 0 \\
 70 - 100 - F &= 0 \\
 F &= -30\text{N}
 \end{aligned}$$

That means the block is try to move downward (F) must be equal or less than (Fmax.)

$$F_{\max.} = \mu \times N$$

$$\begin{aligned}
 + \nwarrow \sum F_y &= 0 \\
 N - 173.2 &= 0 \\
 N &= 173.2\text{N} \\
 F_{\max.} &= 0.2 \times 173.2 = 34.64\text{N} > 30\text{N} \\
 F &= 30\text{N}
 \end{aligned}$$

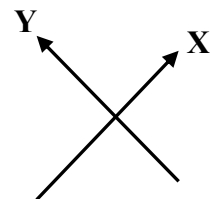
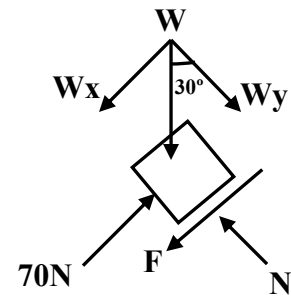

**Example:** Calculate the force (P) required to move the (500N) block weight up the inclined surface shown in figure, if the block is subjected to (200N) force, assume ( $\mu=0.5$ ).

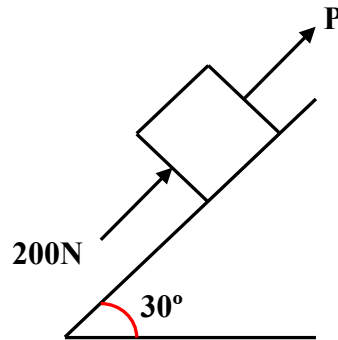

**Solution:**

$$W_x = 500 \times \sin 30 = 250\text{N}$$

$$W_y = 500 \times \cos 30 = 433\text{N}$$

$$+ \nearrow \sum F_y = 0$$

$$N - 433 = 0$$

$$N = 433\text{N}$$

$$F_{\max} = \mu \times N = 0.5 \times 433 = 216.5\text{N}$$

$$+ \nearrow \sum F_x = 0$$

$$200 + P - 250 - 216.5 = 0$$

$$P = 266.5\text{N}$$

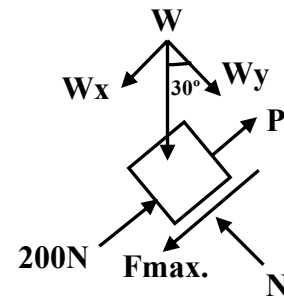

**Example:** A cylinder of (100N) weight, ( $r=70\text{cm}$ ) is to entrust to a horizontal surface its coefficient of friction ( $\mu=0.4$ ) and a smooth vertical surface as shown in figure .Determine the frictional force .

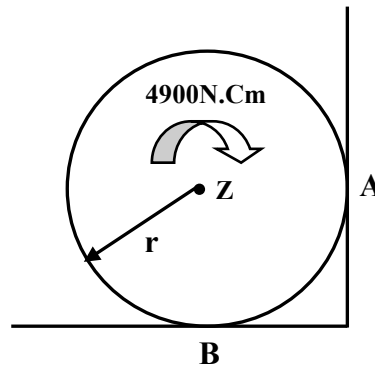

**Solution:**

From F.B.D of cylinder  
Assume FB to the right as shown

$$\begin{aligned}
 + \curvearrowleft \sum M_Z = 0 \\
 - 4900 + F_B \times 70 = 0 \\
 F_B = 70\text{N}
 \end{aligned}$$

FB must be equal or less than (Fmax.)

$$\begin{aligned}
 F_{\text{max.}} &= \mu \times N \\
 + \uparrow \sum F_y = 0 \\
 N_B - 100 &= 0 \\
 N_B &= 100\text{N}
 \end{aligned}$$

$$\begin{aligned}
 F_{\text{max.}} &= 0.4 \times 100 = 40\text{N} < 70\text{N} \\
 F_B &= 40\text{N}
 \end{aligned}$$

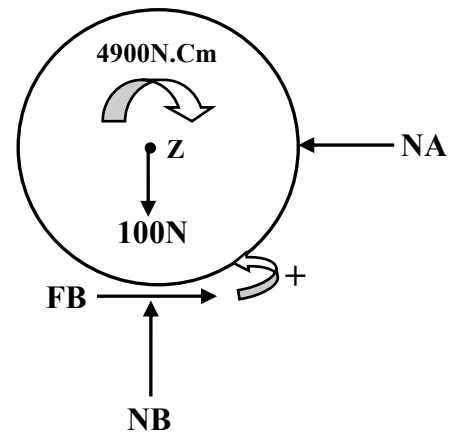

( F.B.D of cylinder)

**Example:** A ladder (300N) weight is rest as shown in figure, if the vertical wall is smooth and the horizontal surface has ( $\mu=0.2$ ). Determine the distance from point (B) which make the ladder move when a boy of (150N) weight try to going up the ladder .

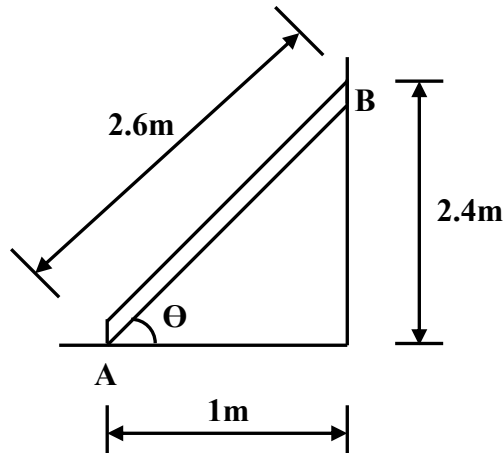

**Solution:**

From F.B.D of ladder:

$$+\uparrow \sum F_y = 0$$

$$N - 300 - 150 = 0$$

$$N = 450\text{N}$$

$$F_{\text{max.}} = \mu \times N$$

$$= 0.2 \times 450 = 90\text{N}$$

$$+\curvearrowright \sum M_B = 0$$

$$- 450 \times 1 + 300 \times 0.5 + 90 \times 2.4 + 150 \times X = 0$$

$$X = 0.56\text{m}$$

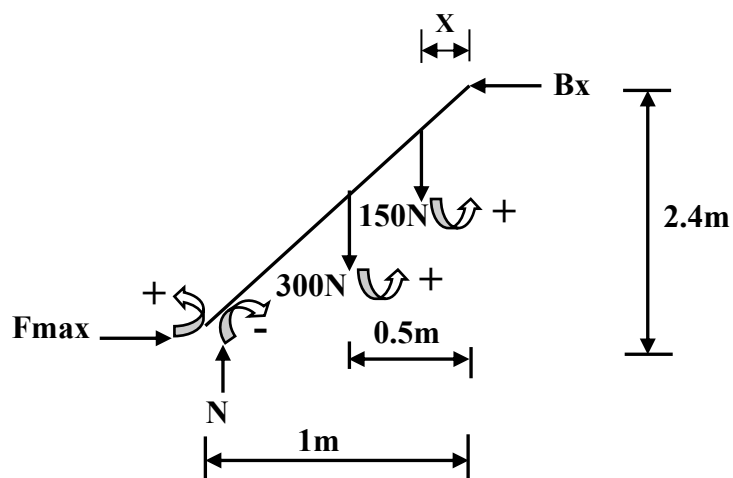
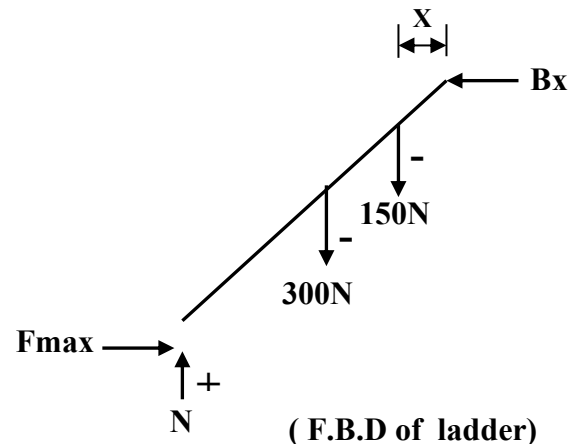

**Example:** Determine the force (P) required to move the (400N) block weight shown in figure if the horizontal surface has ( $\mu = 0.34$ ).

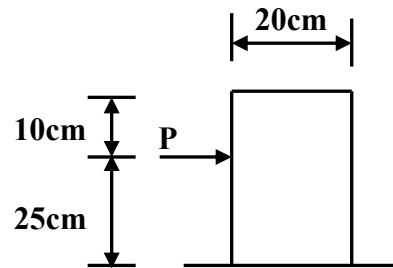

**Solution:**

The block is either slides or overturn

1-the block is slides From (F.B.D 1)

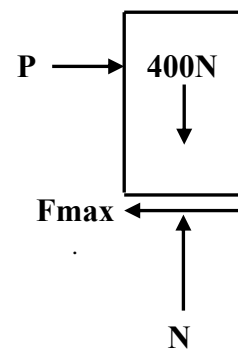

**F.B.D 1**

$$+ \uparrow \sum F_y = 0$$

$$N - 400 = 0$$

$$N = 400\text{N}$$

$$F_{\text{max.}} = \mu \times N$$

$$= 0.34 \times 400 = 136\text{N}$$

$$+ \rightarrow \sum F_x = 0$$

$$P - 136 = 0$$

$$P = 136$$

2-the block is overturn From (F.B.D 2)

$$+ \curvearrowright \sum M_A = 0$$

$$- P \times 25 + 400 \times 10 = 0$$

$$P = 160\text{N}$$

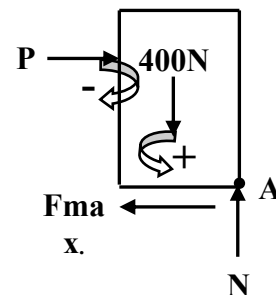

**F.B.D 2**

The block is slides and  $P = 136\text{N}$

## CENTROID

### STRENGTH OF MATERIALS

Deals with relations between external loads and their internal effects on bodies.

STRESS:  $\sigma$

Is the unit strength of a material and can be calculated by:

$$\sigma = \frac{P}{A}$$



**P:** axial force

**A:** cross sectional area

Units of stress: N/m<sup>2</sup>= Pa. (Pascal)  
MPa. =Mega Pascal =10<sup>6</sup> Pa. = N/mm<sup>2</sup>

Types of stresses:

1:- Tensile stress



2:- Compressive stress

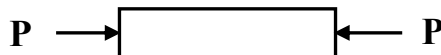

Example: An aluminum bar of (40mm) diameter carries an axial load of (12560N).  
Determine the stress in the bar.

Solution:

$$\sigma = P/A$$

$$r = 40/2 = 20\text{mm}$$

$$\text{Cross sectional area (A)} = \pi \times r^2 = \pi \times (20/1000)^2 = \pi \times 400/10^6 = 1256 \times 10^{-6} \text{ m}^2$$

$$\sigma = 12560/1256 \times 10^{-6} = 10\text{pa.} = 10 \text{ MPa.} \cdot 10^6 \times$$

**Example:** An aluminum tube is rigidly fastened between a bronze bar and a steel bar. Axial loads are applied as shown in figure. Determine the stress in each material.

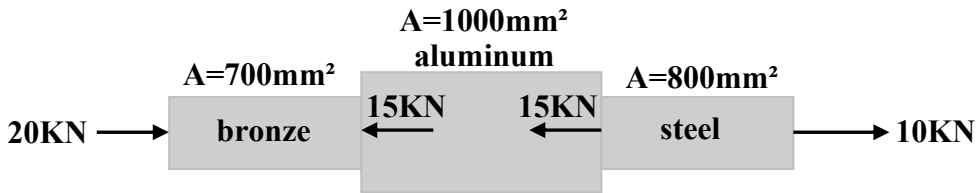

**Solution:**

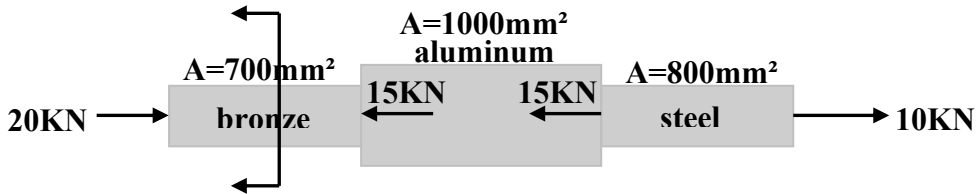

$$\sigma = P/A$$

$$P_b = \sum F_x = 20 \text{ kN}$$

$$\sigma_b = 20 \times 1000 / 700 \times 10^6$$

$$= 28.57 = 28.57 \text{ MPa. (C)} \quad 10^6 \times$$

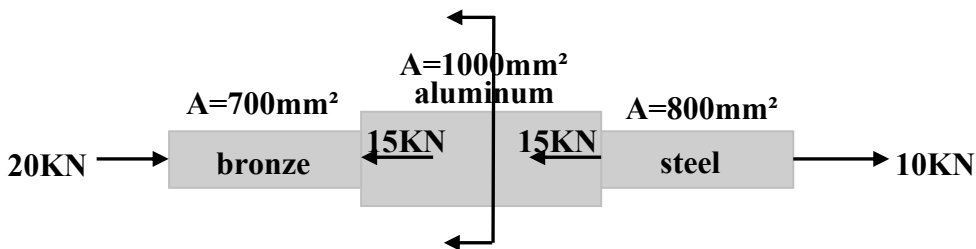
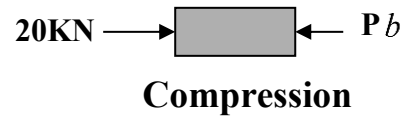

$$\sigma = P/A$$

$$P_a = \sum F_x = 20 - 15 = 5 \text{ kN}$$

$$\sigma_a = 5 \times 1000 / 1000 \times 10^6$$

$$= 5 \text{ pa} = 5 \text{ MPa. (C)} \quad a \times$$

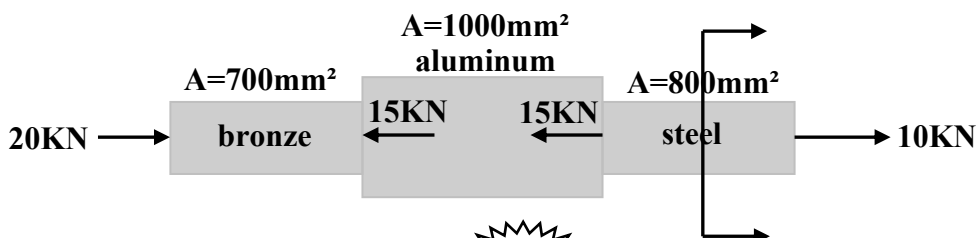
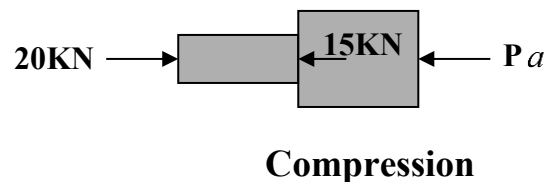

$$\sigma = P/A$$

$$P S = \sum F_x = 10 \text{KN}$$

$$\sigma_s = 10 \times 1000 / 800 \times 10^3$$

$$= 12.5 \times 10^6 \text{ pa} = 12.5 \text{ MPa. (T)}$$



Tension

**Example:** Determine the maximum safe load (P) which may be applied on the steel plate shown in figure if the average tensile stress is (160 MPa.).

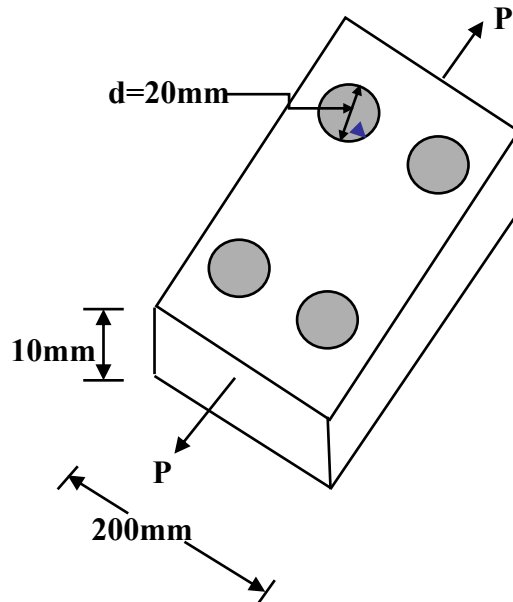

**Solution:**

$$\sigma = P/A$$

$$\text{Area of section} = 200 \times 10 = 2000 \text{mm}^2$$

$$\text{Area of two holes} = 2 \times 20 \times 10 = 400 \text{mm}^2$$

$$\text{Net area of section} = 2000 - 400$$

$$= 1600 \text{ mm}^2$$

$$= 1600 \times 10^{-6} \text{ m}^2$$

$$\sigma = P/A$$

$$P = A \times \sigma$$

$$= 1600 \times 10^{-6} \times 160$$

$$= 256000 \text{ N} = 256 \text{KN}$$

$10^6 \times$

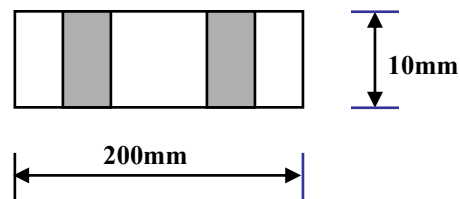
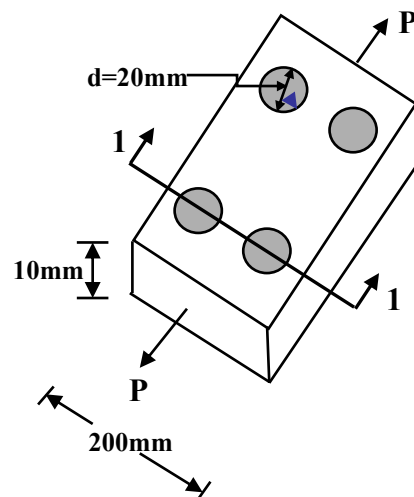

Section 1-1

**Example:** A (18kN) weight is supported by two steel wires as shown in figure. Determine the cross sectional area of each wire if the tensile stresses in the wires are limited to (100 MPa.) .

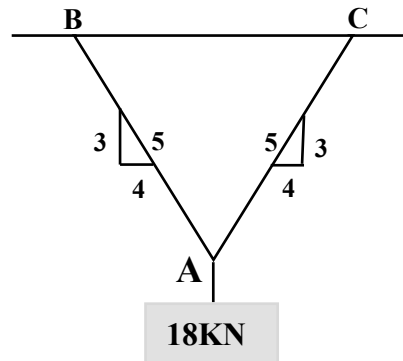

**Solution:**

$$\sum F_x = 0$$

$$T_2 \times \frac{4}{5} - T_1 \times \frac{4}{5} = 0$$

$$T_1 = T_2 = T$$

$$\sum F_y = 0$$

$$T \times \frac{3}{5} + T \times \frac{3}{5} - 18 = 0$$

$$T \times \frac{6}{5} = 18$$

$$6T = 90$$

$$T = 15 \text{ kN}$$

$$T = 90/6 = 15 \text{ kN}$$

$$\sigma = P/A$$

$$A = P/\sigma$$

$$= 15 \times 1000 / 100 \times 10^6 \times$$

$$= 150 \times 10^{-6} \text{ m}^2$$

$$= 150 \text{ mm}^2$$

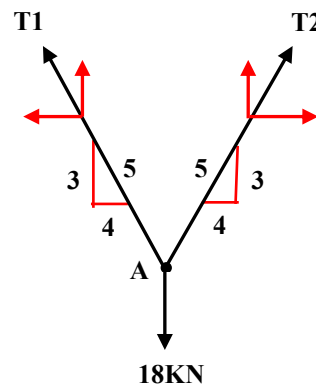

3:- Shearing stress:  $\tau$

it is caused by a force acting parallel to area resisting the force.

$$\tau = \frac{V}{A}$$

V: shearing force

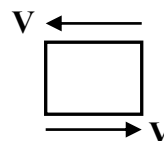

**A:** area of parallel cross section

**Example:** Determine the shearing stress in the rivet shown in figure due to the (30KN) applying load if the diameter of the rivet is (20mm).

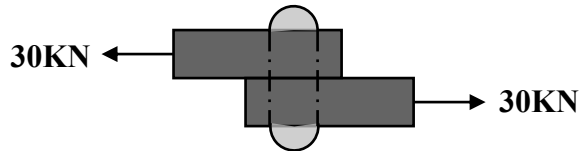

**Solution**

$$\tau = \frac{V}{A}$$

$$V = 30\text{KN} = 30 \times 1000 = 30000\text{N}$$

$$d = 20 + 1.5 = 21.5\text{mm}$$

$$r = 21.5 / 2 = 10.75\text{mm}$$

$$A = \pi \times (10.75)^2 = 363 \text{ mm}^2 = 362.86 \times 10^{-6} \text{ m}^2$$

$$\tau = \frac{V}{A}$$

$$= 30000 / 362.86 \times 10^{-6} = 82.67 \times 10^6 \text{ Pa} = 82.67 \text{ MPa}.$$

**4:-Bearing stress:**

Is a contact pressure between separate bodies such as the soil pressure, force on bearing plate.

**STRAIN:**  $\mathcal{E}$   
Is the unit deformation caused by stress  
Strain = Change in length / Original length

$$\mathcal{E} = \frac{\delta}{L}$$

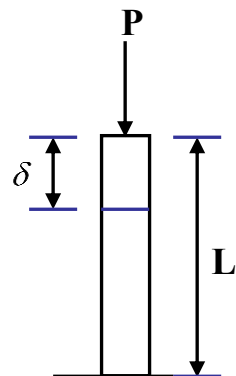

**Example:** Determine the strain of a body caused by the applied force (P) if the decrease in length is (2cm) , and the length of the body is (200cm) .

**Solution:**

$$\mathcal{E} = \delta / L$$

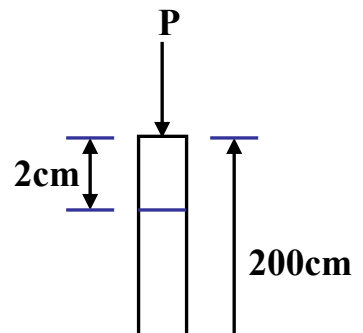

$$= 2/200 = 0.01$$

**HOOK'S LAW:**      *Axial deformation*

The slope of stress-strain curve (straight line portion) = modulus of Elasticity = E

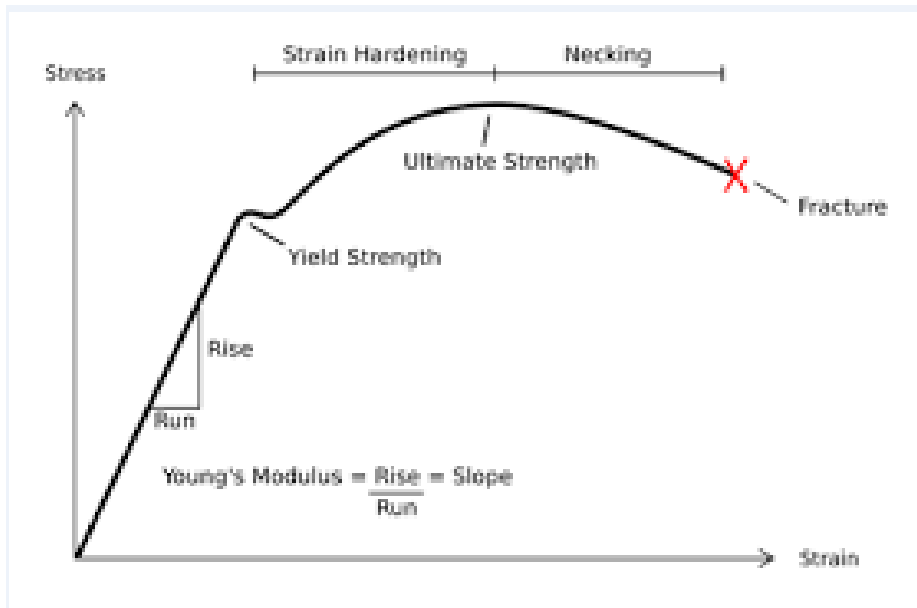

$$E = \sigma / \epsilon \quad \Rightarrow \quad \sigma = E * \epsilon$$

**NOTE:** the units of (E) are the same units of stress, for example:

E for steel = 200 Pa. = 200 GPa.  $10^9 \times$

E for aluminum = 70 Pa. = 70 GPa.  $10^9 \times$

GPa. = Gega Pascal =  $10^9$  Pa.

$$\sigma = E * \epsilon$$

$$P/A = E * \delta / L$$

$$\delta = \frac{PL}{AE}$$

**POISSON'S RATIO:**

*v*

$\nu = \text{Lateral strain} / \text{Longitudinal strain}$

$$\nu = \epsilon_y / \epsilon_x$$

**Example:** A steel wire (8m) long hanging vertically support a tensile load of (4000N). Determine the required diameter and the elongation in the wire if the stress is not exceed (50Mpa.) . Assume  $E_s=200\text{Gpa}$ .

**Solution:**

$$\sigma = \frac{P}{A}$$

$$50 = 10^6 \times \frac{4000}{A}$$

$$A = \frac{4000}{50 \times 10^6} = 80 \times 10^{-6} \text{m}^2 = 80 \text{mm}^2$$

$$A = \pi r^2$$

$$80 = \pi r^2$$

$$r^2 = 80 / \pi = 25.46 \text{mm}^2 \quad \rightarrow \quad r = 5.05 \text{mm} \quad \rightarrow \quad d = 5.05 \times 2 = 10.1 \text{mm}$$

$$\delta = \frac{PL}{AE} = \frac{4000 \times 8}{80 \times 10^{-6} \times 200 \times 10^9} = 2 \times 10^{-3} \text{m} = 2 \text{mm}$$

**Example:** A uniformly bar of ( $1 \times 10^{-4} \text{m}^2$ ) area. Axial loads are applied as shown in figure. Find the total deformation. Assume ( $E=200\text{GPa}$ ).

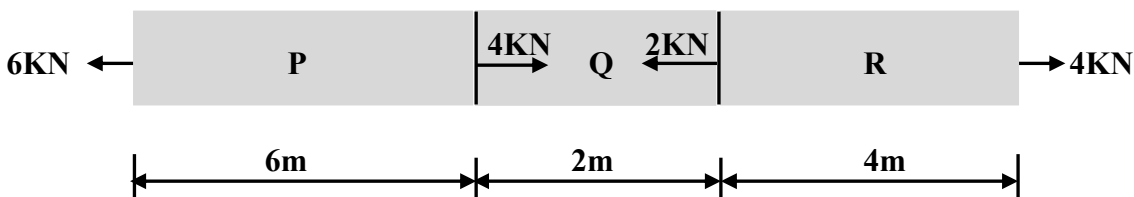

**Solution:**

$$\delta = \frac{PL}{AE}$$

$$\delta_P = 6 \times 1000 \times 6 / 1 \times 10^{-4} \times 200 \times 10^9$$

$$= 0.0018 \text{m} = 1.8 \text{mm} (+)$$

$$\delta_Q = 2 \times 1000 \times 2 / 1 \times 10^{-4} \times 200 \times 10^9$$

$$= 0.0002 \text{m} = 0.2 \text{mm} (+)$$

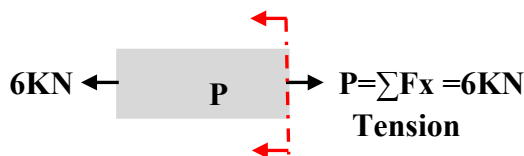

$$\delta_R = 4 \times 1000 \times 4 / 1 \times 10^{-4} \times 200 \times 10^9$$

$$= 0.0008 \text{ m} = 0.8 \text{ mm (+)}$$

$$\delta_{\text{total}} = 1.8 + 0.2 + 0.8$$

$$= 2.8 \text{ mm}$$

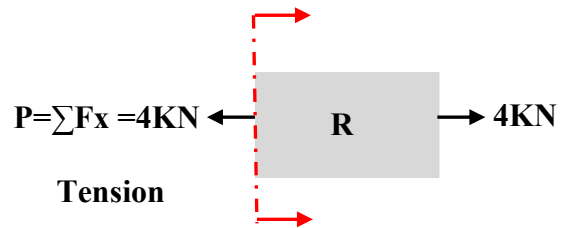

**Example:** uniform concrete beam of mass (1200kg) will remain level after it is attached to a steel and aluminum rods as shown in figure. Determine:  
 1-the vertical movement of the beam.  
 2-the cross sectional area of steel rod.

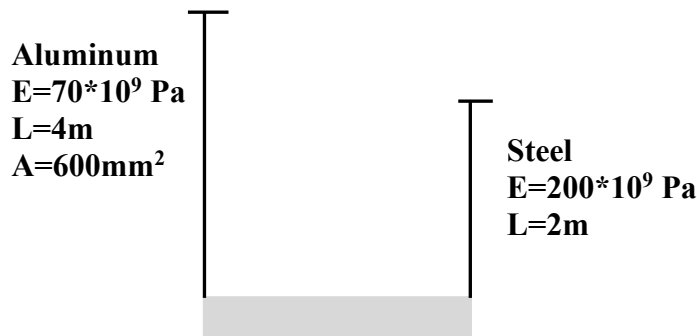

**Solution:**

$$\delta_s = \frac{PL}{AE}$$

$$\text{Weight of beam} = 1200 \times 9.8 = 11760 \text{ N}$$

$$T_s = T_a = \frac{11760}{2} = 5880 \text{ N}$$

$$\delta = \frac{PL}{AE} = \frac{5880 \times 4}{600 \times 10^{-6} \times 70 \times 10^9} = 0.56 \times 10^{-3} \text{ m} = 0.56 \text{ mm}$$

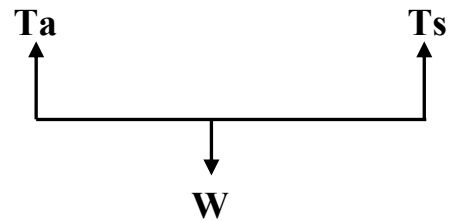

The beam will remain level after it is attached, then

$$\delta_s = \delta_a$$

$$\delta_s = \frac{PL}{AE}$$

$$0.56 \times 10^{-3} = \frac{5880 \times 2}{A \times 200 \times 10^9}$$

$$A = \frac{5880 \times 2}{0.56 \times 10^{-3} \times 200 \times 10^9} = 105 \times 10^{-6} \text{ m}^2 = 105 \text{ mm}^2$$

## SHEAR FORCE AND BENDING MOMENT DIAGRAMS FOR BEAMS

**Shear force:** is the summation of vertical external loads acting on the left side of the selected section.

**Bending moment:** is the summation of moments of all the loads acting to the left of the selected section.

$$V = (\sum F_y)_L$$

$$M = (\sum M)_L$$

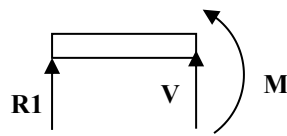

**Example:** Draw shear force and bending moment diagrams for the beam loaded as shown in figure.

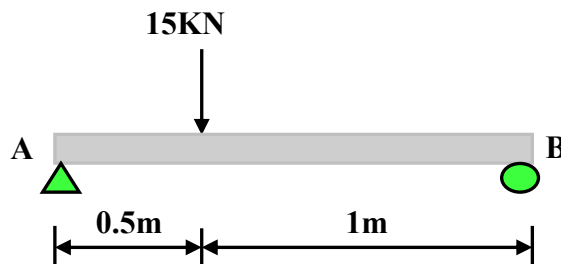

**Solution:**

**1-determination of reactions**

$$\sum F_x = 0 \quad A_x = 0$$

$$+ \curvearrowleft \sum M_A = 0$$

$$B_y \times 1.5 - 15 \times 0.5 = 0$$

$$B_y = 5\text{kN}$$

$$\sum F_y = 0$$

$$A_y + 5 - 15 = 0$$

$$A_y = 10\text{kN}$$

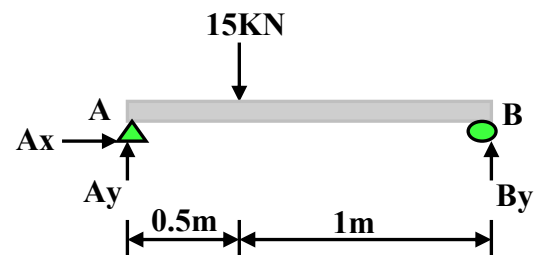

**2-Drawing of S.F.D and B.M.D written the equations at section (1-1) and (2-2).**

**Section (1-1)**

$$V_1 = \sum F_y = 10 \text{ KN}$$

$$+ \curvearrowright M_1 = \sum M = 10X$$

When  $X=0$   $M_1=0$   
 When  $X=0.5$   $M_1=5 \text{ KN.m}$

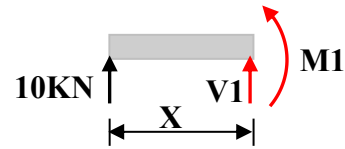

**Section (2-2)**

$$V_2 = \sum F_y = 10 - 15 = -5 \text{ KN}$$

$$+ \curvearrowright M_2 = \sum M = 10X - 15(X - 0.5)$$

When  $X=0.5$   $M_2 = 10 \cdot 0.5 - 15 \cdot (0.5 - 0.5) = 5 \text{ KN.m}$   
 When  $X=1.5$   $M_2 = 10 \cdot 1.5 - 15 \cdot (1.5 - 0.5) = 0$

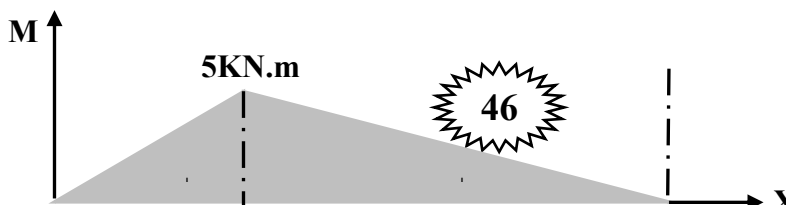
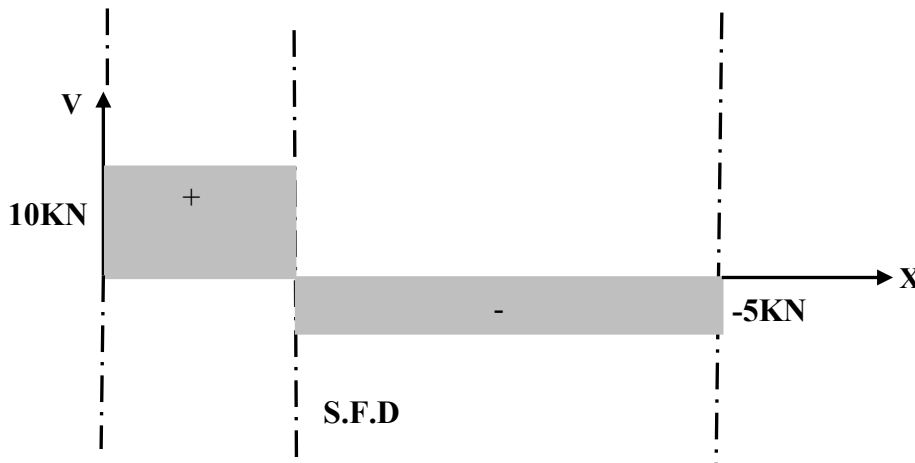
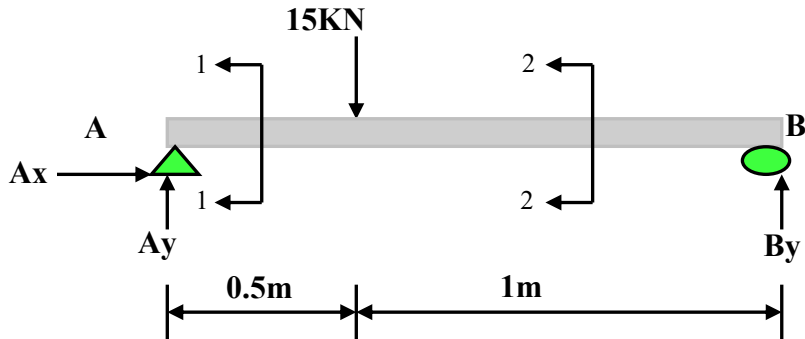
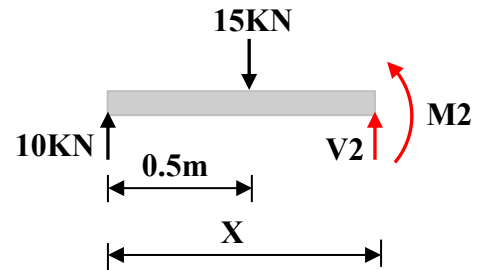

**Example:** Draw shear force and bending moment diagrams for the beam loaded as shown in figure .

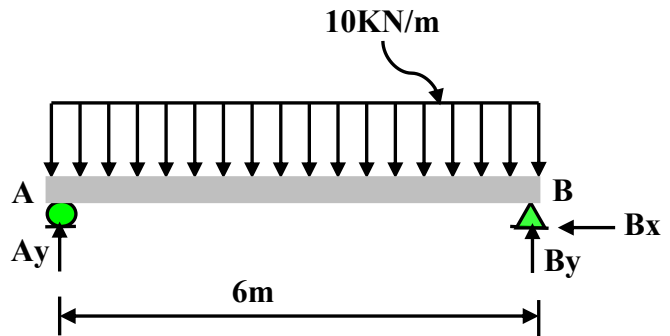
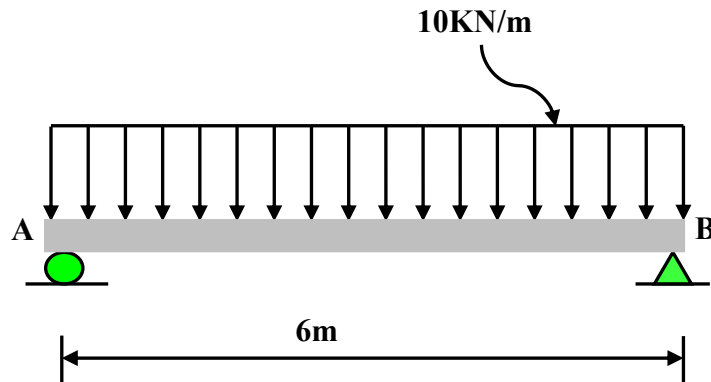

**Solution:**

1-determination of reactions

$$R = 10 \times 6 = 60 \text{ kN}$$

$$\sum F_x = 0 \quad B_x = 0$$

$$+ \curvearrowright \sum M_A = 0$$

$$B_y \times 6 - 60 \times 3 = 0$$

$$B_y = 30 \text{ kN}$$

$$\sum F_y = 0$$

$$A_y + 30 - 60 = 0$$

$$A_y = 30 \text{ kN}$$

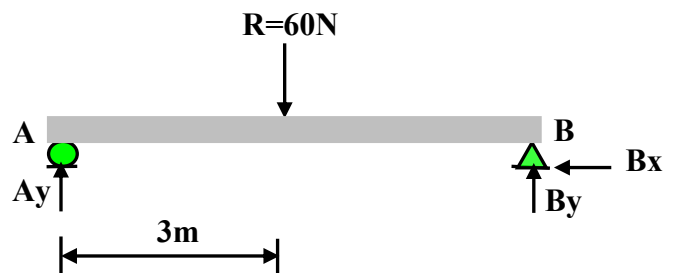

F.B.D

**2-Drawing of S.F.D and B.M.D by written the equations at section (1-1)**

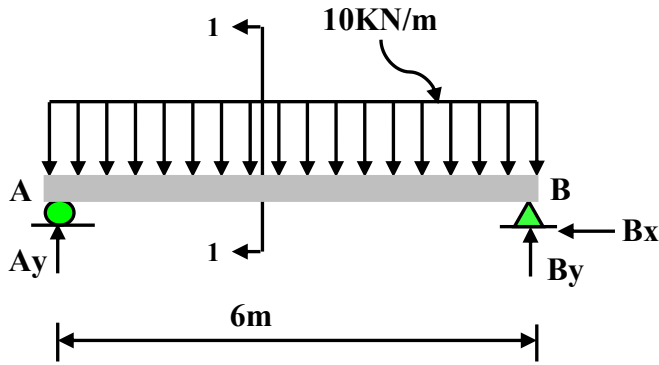

**Section (1-1)**

$$R=10X$$

$$V=\sum Fy=30-10X$$

$$\text{when } X=0 \quad V1=30\text{KN}$$

$$\text{when } X=6 \quad V1= -30\text{KN}$$

$$+ \curvearrowright M=\sum M=30X-10X(X/2) =30X-5X^2$$

$$\text{when } X=0 \quad M1=0$$

$$\text{when } X=6 \quad M1=0$$

**Note: the maximum bending moment caused when  $V=0$**

therefore:

$$V=30-10X$$

$$0=30-10X$$

$$30=10X$$

$$X=30/10=3\text{m}$$

when  $X=3$

$$M_{max.}=30*3-5*3^2$$

$$=90-45= 45\text{KN.m}$$

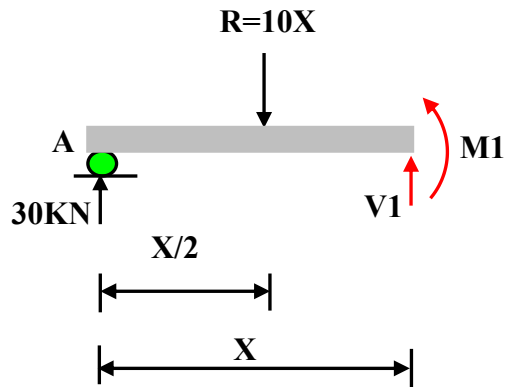
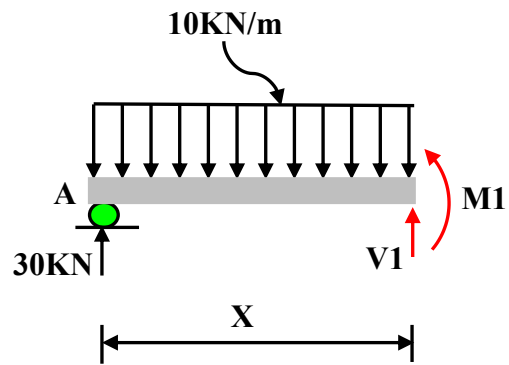

F.B.D

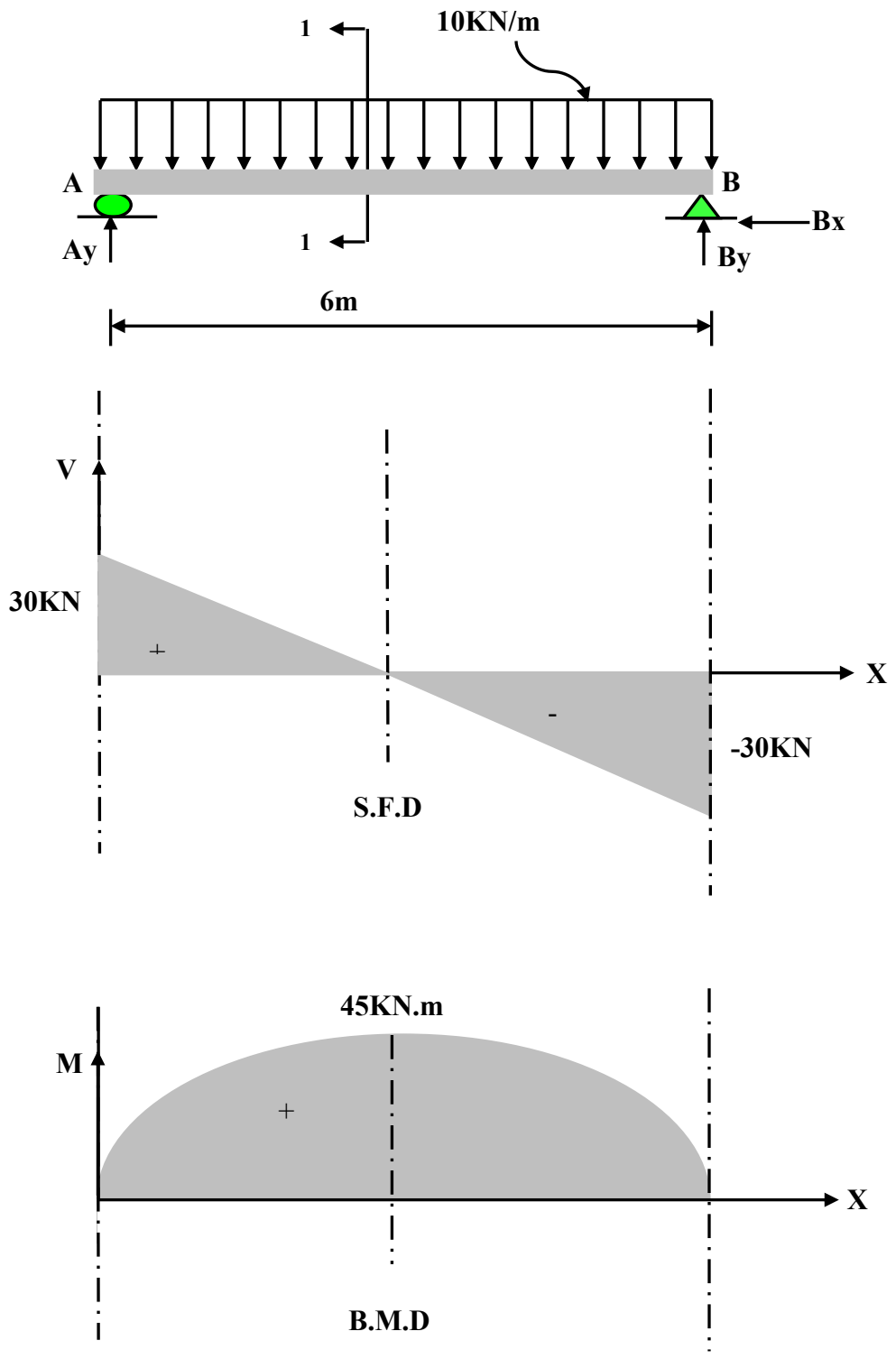

**Example:** Draw shear force and bending moment diagrams for the beam loaded as shown in figure.

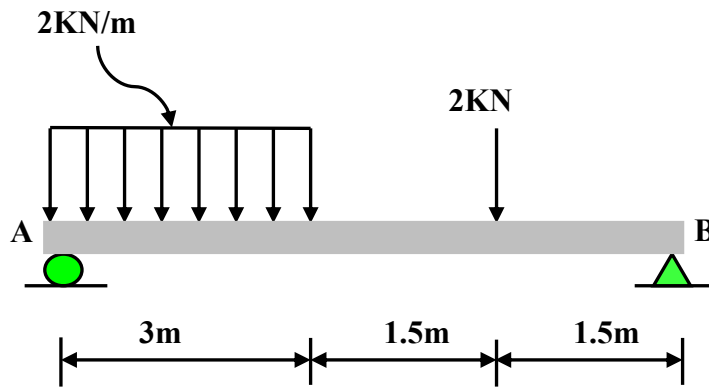

**Solution:**

1-determination of reactions

$$R = 3 \times 2 = 6 \text{ kN}$$

$$\sum F_x = 0 \quad B_x = 0$$

$$+ \curvearrowright \sum M_A = 0$$

$$B_y \times 6 - 2 \times 4.5 - 6 \times 1.5 = 0$$

$$B_y = 3 \text{ kN}$$

$$\sum F_y = 0$$

$$A_y + 3 - 6 - 2 = 0$$

$$A_y = 5 \text{ kN}$$

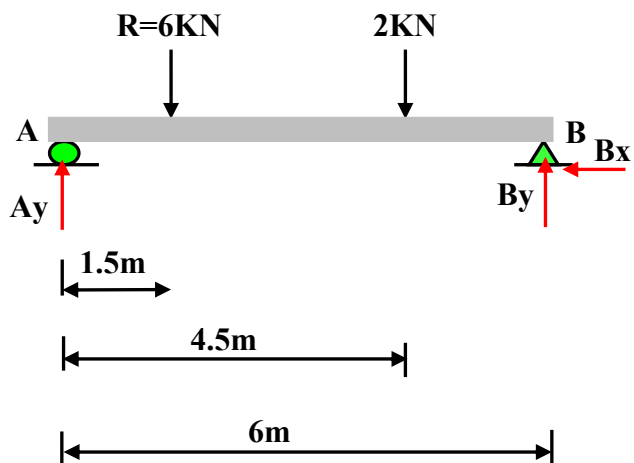
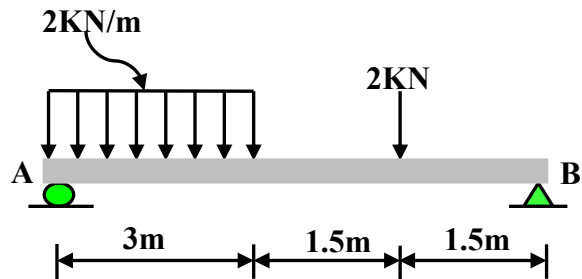

F.B.D

**2-Drawing of S.F.D and B.M.D by written the equations at sections (1-1) , (2-2) and (3-3).**

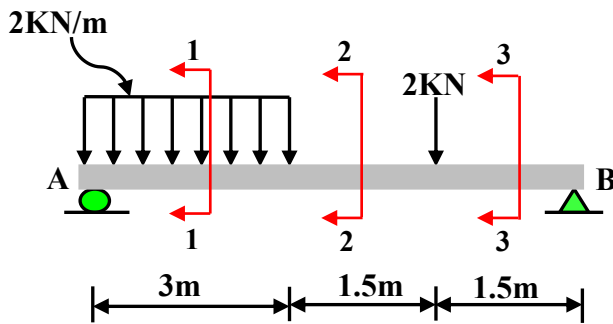

**Section (1-1)**

$R=2X$

$V1=\sum Fy= 5-2X$

when  $X=0$   $V1=5\text{KN}$

when  $X=3$   $V1= 5 -(2* 3)= -1\text{KN}$

$+ \curvearrowright M1=\sum M=5X-2X(X/2) =5X-X^2$

when  $X=0$   $M1=0$

when  $X=3$   $M1=(5*3)-3^2=6\text{KN.m}$

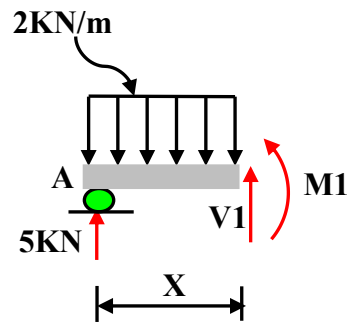

**Note: the maximum bending moment caused when  $V=0$**

**therefore:**

$V1=5-2X$

$0=5-2X$

$5=2X$

$X=5/2=2.5\text{m}$

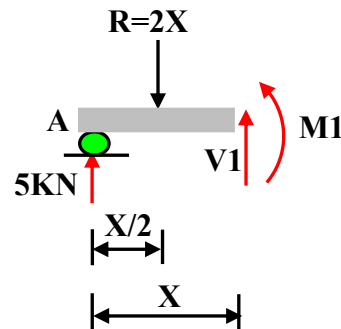

when  $X=2.5$

$M_{\text{max.}}= 5X-X^2$

$=5*2.5-2.5^2= 6.25\text{KN.m}$

Section (2-2)

$$R = 2 \times 3 = 6 \text{KN}$$

$$V_2 = \sum F_y = 5 - 6 = -1 \text{KN}$$

$$\begin{aligned}
 + \curvearrowright M_2 &= \sum M = 5X - 6(X - 1.5) \\
 &= 5X - 6X + 9 \\
 &= 9 - X
 \end{aligned}$$

when  $X = 3$        $M_2 = 9 - 3 = 6 \text{KN.m}$

when  $X = 4.5$        $M_2 = 9 - 4.5 = 4.5 \text{KN.m}$

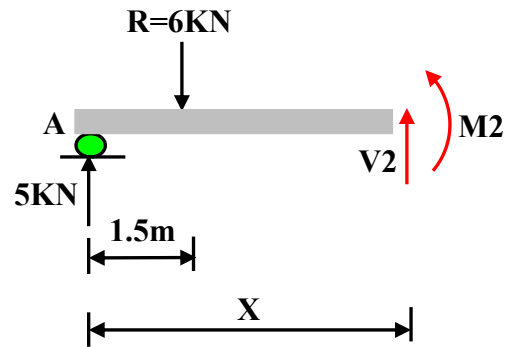
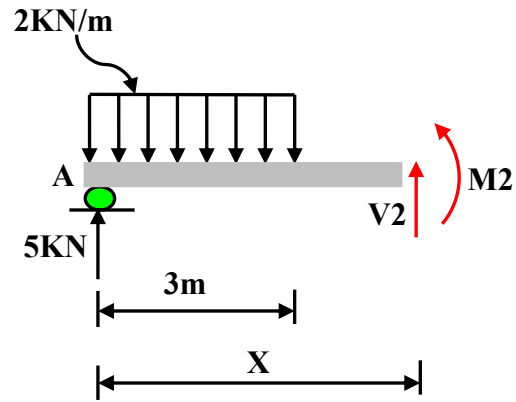

Section (3-3)

$$R = 2 \times 3 = 6 \text{KN}$$

$$V_3 = \sum F_y = 5 - 6 - 2 = -3 \text{KN}$$

$$\begin{aligned}
 + \curvearrowright M_3 &= \sum M = 5X - 6(X - 1.5) - 2(X - 4.5) \\
 &= 5X - 6X + 9 - 2X + 9 \\
 &= 18 - 3X
 \end{aligned}$$

when  $X = 4.5$        $M_3 = 18 - 3 \times 4.5 = 4.5 \text{KN.m}$

when  $X = 6$        $M_3 = 18 - 3 \times 6 = 0 \text{KN.m}$

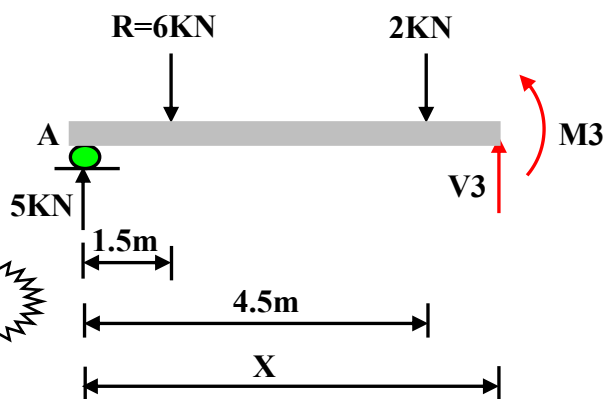
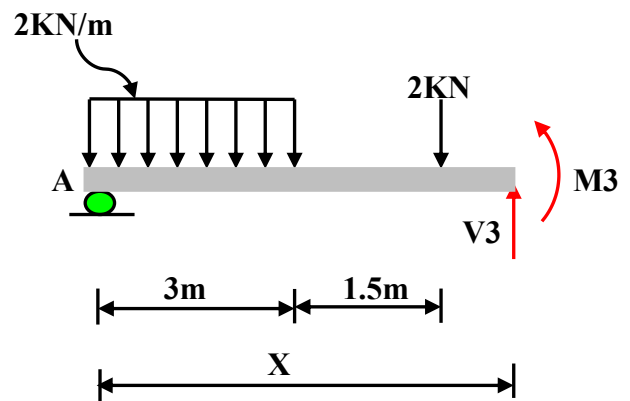

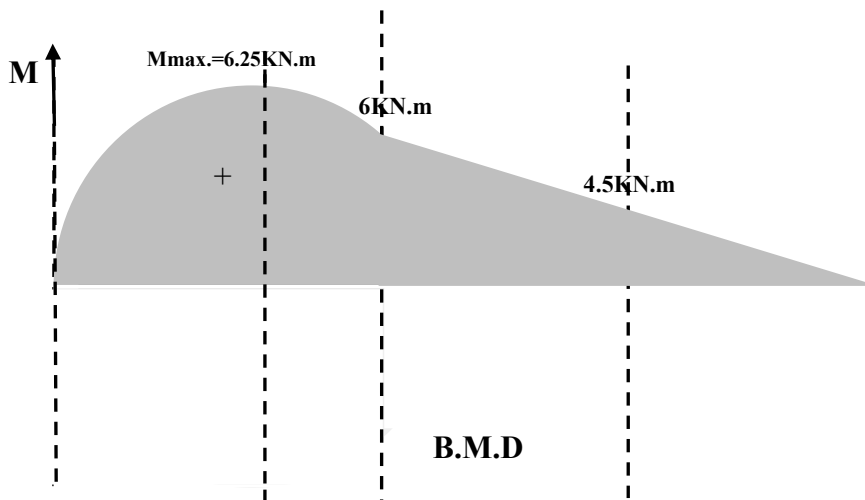
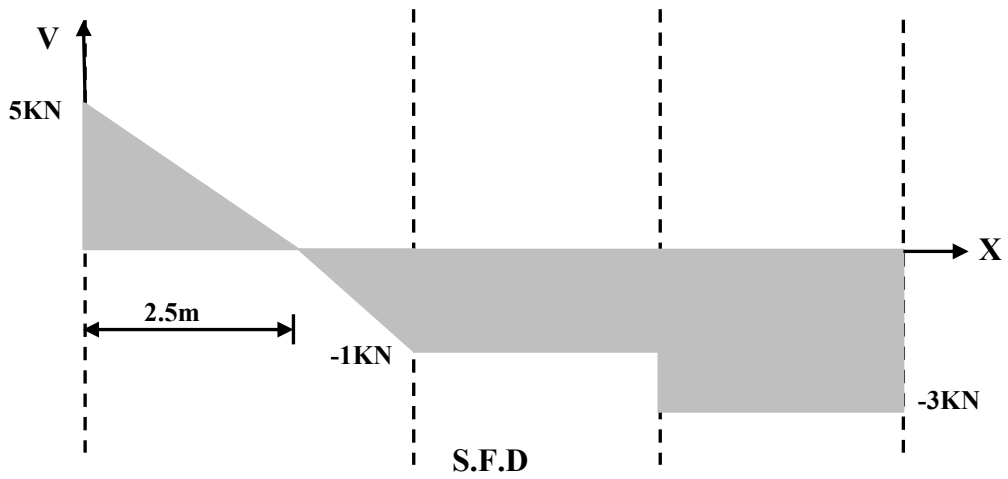
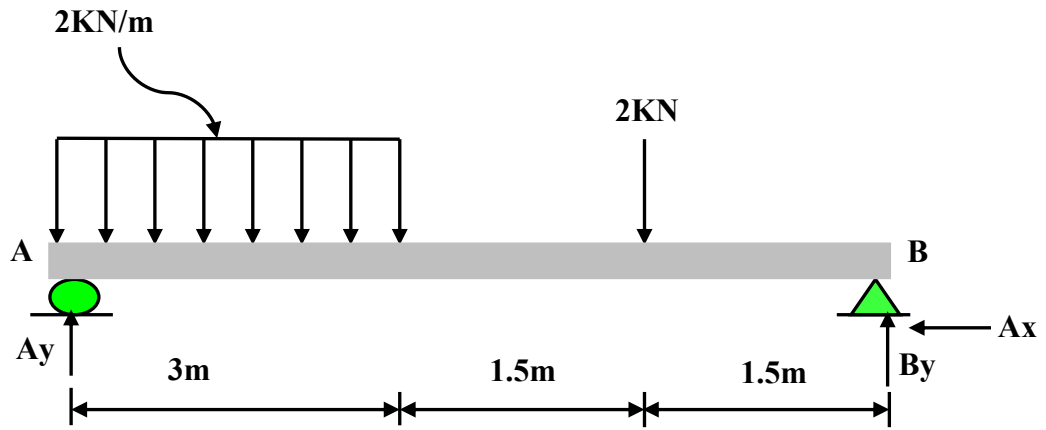

**STRESSES IN BEAMS: (Rectangular sections)**

**1:-Bending stress: (Flexure stress)**

Is the stress caused by the bending moment.

**Flexure formula: is the relation between bending stress and the bending moment.**

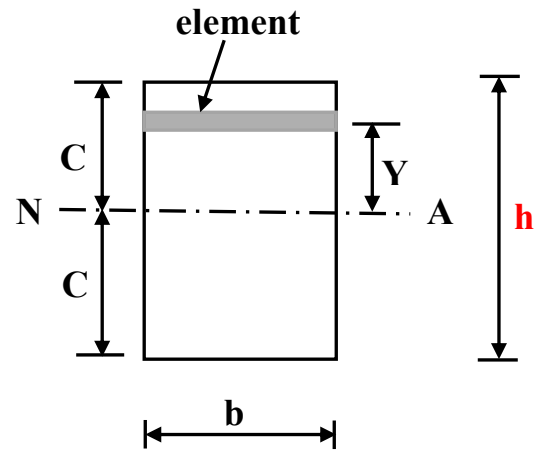
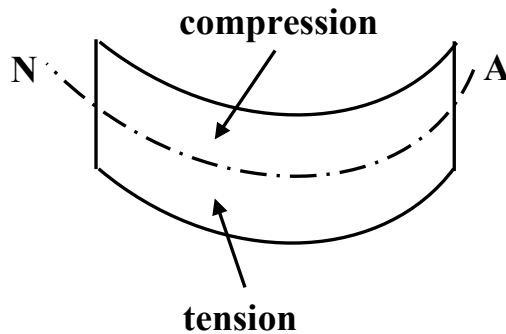
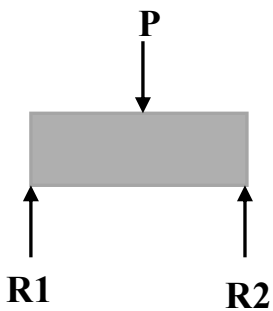

$$\sigma = \frac{MY}{I}$$

$\sigma$  = flexure stress (N/m<sup>2</sup>) at a distance Y from N.A

Y = distance from N.A to element

M = maximum bending moment at the section

I = moment of inertia of the section =  $bh^3 / 12$

$$\sigma_{max.} = \frac{MC}{I}$$

$\sigma_{max.}$  = maximum flexure stress

C = the distance from N.A to the top or bottom of the section =  $h / 2$

2:-Shearing stress:  $\tau$

$$\tau = \frac{V \hat{A} \bar{Y}}{I b}$$

$\hat{A}$  =shaded area

$\bar{Y}$  =distance from centroid of  $\hat{A}$  to the N.A

$V$  =maximum shearing force

$$\tau_{max.} = \frac{3V}{2A} \quad A = b \times h$$

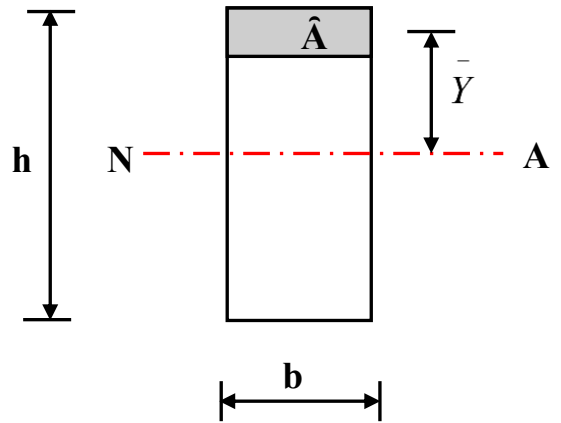

Example: A cantilever beam (110mm) wide by (220mm) height if  $M_{max.} = 10.75 \text{KN.m}$ , and  $V_{max.} = 8 \text{KN}$ . Determine:-  
 1- the maximum flexure stress  
 2- the maximum shear stress

Solution:

$$\sigma_{max.} = \frac{MC}{I}$$

$$C = 220 / 2 = 110 \text{mm} = 0.11 \text{m}$$

$$\begin{aligned} I &= bh^3 / 12 = (110 \times 10^{-3}) \times (220 \times 10^{-3})^3 / 12 \\ &= 110 \times 10^{-3} \times 10648000 \times 10^{-9} / 12 \\ &= 110 \times 10^{-3} \times 10648 \times 10^3 \times 10^{-9} / 12 \\ &= 97606.66 \times 10^{-9} \\ &= 97.606 \times 10^3 \times 10^{-9} = 97.606 \times 10^{-6} \text{ m}^4 \end{aligned}$$

$$\sigma_{max.} = \frac{10.75 \times 1000 \times 0.11}{97.606 \times 10^{-6}} = 12.11 \times 10^6 \text{ pa.} = 12.11 \text{ Mpa.}$$

$$\tau_{max.} = \frac{3V}{2A}$$

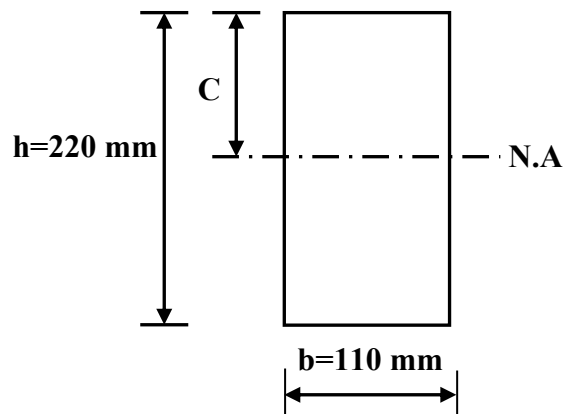

$$A = b \times h = (110 \times 10^{-3}) \times (220 \times 10^{-3}) = 24200 \times 10^{-6}$$

$$\tau_{max.} = \frac{3 \times 8 \times 1000}{2 \times 24200 \times 10^{-6}} = 0.49 \times 10^6 \text{ Pa.} = 0.49 \text{ MPa.}$$

**Example:** Determine the minimum width (**b**) of a beam if the flexural stress is not exceed ( $12 \times 10^6 \text{ Pa.}$ ), ( $M_{max.} = 5000 \text{ N.m}$ ) and its height ( $h = 200 \text{ mm}$ ).

**Solution:**

$$\sigma_{max.} = \frac{MC}{I}$$

$$C = 200 / 2 = 100 \text{ mm} = 0.1 \text{ m}$$

$$\sigma_{max.} = \frac{MC}{I}$$

$$12 \times 10^6 = 5000 \times 0.1 / I$$

$$I = 5000 \times 0.1 / 12 \times 10^6 = 41.66 \times 10^{-6} \text{ m}^4$$

$$I = bh^3 / 12$$

$$h = (200 / 10^3) = 200 \times 10^{-3} \text{ m}$$

$$41.66 \times 10^{-6} = b \times (200 \times 10^{-3})^3 / 12$$

$$41.66 \times 10^{-6} = b \times 8000000 \times 10^{-9} / 12$$

$$41.66 \times 10^{-6} \times 12 = b \times 8 \times 10^6 \times 10^{-9}$$

$$b = 41.66 \times 10^{-6} \times 12 / 8 \times 10^6 \times 10^{-9}$$

$$b = 62.49 \times 10^{-3} \text{ m} = 62.49 \text{ mm}$$

